



# Development of a Web Module for Automatic Farm Management

**EVINA Nkolo Williams Mathias<sup>1\*</sup>, Julius Kewir Tangka<sup>1</sup>,  
Djousse K. Boris Merlain<sup>1</sup>, John Ngansi Nga<sup>1</sup> and Tedongmo Gouana Jospin<sup>1</sup>**

<sup>1</sup>Department of Agricultural Engineering, Faculty of Agronomy and Agricultural Sciences, University of Dschang, Cameroon.

## **Authors' contributions**

*This work was carried out in collaboration among all authors. All authors read and approved the final manuscript.*

## **Article Information**

DOI: 10.9734/CJAST/2021/v40i2231478

### Editor(s):

(1) Dr. Chien-Jen Wang, National University of Tainan, China.

### Reviewers:

(1) Raheel Muzzammel, University of Lahore, Pakistan.

(2) Chen Hongyu, China University of Mining and Technology, China.

Complete Peer review History: <https://www.sdiarticle4.com/review-history/72490>

**Original Research Article**

**Received 13 June 2021  
Accepted 23 August 2021  
Published 07 September 2021**

## **ABSTRACT**

Frequent visits to livestock farms for cleaning, feed and water distribution are possible ways of spreading viruses and bacteria. An automatic feed distribution and water management system can significantly reduce the workload by helping to control transmissible animal diseases. To this end, an automatic solar-powered module for feed and water distribution, sanitation management, and communication via the global mobile communications system and the internet through a web application has been developed for livestock farms. This module consists of an Arduino Mega board, water and feed level sensors, a "Reel Time Clock", relay modules, an LCD screen, a "Global System for Mobile Communications" module and a web application. Initial testing of the prototype revealed a minimum efficiency of 83.33% for all units. Field and laboratory tests indicated that the module is capable of communicating with the farmer 1 to 3 seconds after completion of each task. It was concluded that the use of this module can seriously limit the visits to the farms, thus reducing the drudgery of the work and the possibility of spreading diseases.

**Keywords:** *Animal farm; automatic management; solar energy; internet of things; web application.*

\*Corresponding author: E-mail: [evinamathias@yahoo.fr](mailto:evinamathias@yahoo.fr);

## 1. INTRODUCTION

Farms are often considered as elementary units of space and rural landscape structuring. Livestock farming plays an important role in the life of the populations of the Central African sub-region in general and Cameroon in particular. In this region, the production of beef cattle, dairy cattle, sheep, goats, pigs and poultry can be observed in small and large farms as well as in the domestic environment. Despite the economic impact of this activity on the national economy, activities in this sector are still carried out manually with local labour and rudimentary MINEPIA technology [1]. Methods derived from the automation of agricultural systems are providing interesting advances in this area, Schewe and Stuart [2]. Thus, these methods are indispensable and offer a great advantage for the world of agriculture in general and for livestock farmers in particular, Roels [3]. Faced with difficulties such as: the problems of contamination of the subjects due to contact with the outside world; the problems of distance from the farms; the sometimes very difficult human loads; climatic problems; time problems; lack of manpower; the discomfort of the subjects in the farms due to the difficulty of maintenance; agricultural systems have been developed, mechanised and automated allowing us to construct a problem, Landais and Weisslinger [4]. Therefore, how can we generally manage animal husbandry almost independently of humans using a Global System for Mobile Communications (GSM) and a web application without interrupting electrical power? In other words, how do we develop a web application for managing an animal farm with uninterrupted power?

As a literature review, we can observe: Tangka and A/s paper in 2021, which presents the automation of watering, feeding and cleaning of an animal farm by GSM and storage of data in an SD memory card, Tangka and A/ [5]. We thus highlight the limitation of communicating with the farmer only done by GSM and storing data in a memory card, while a backup in a database can be ideal and can facilitate the operation. The journal "*Bilan d'activité*" 2017 of the IFIP farm which positions its experimental station, a development platform for livestock management. The idea of this BEALIM project is to have as much individual data as possible on the herd of pregnant sows in order to feed them accurately and to create alert tools on the health of the subjects, Ifip-institut du porc [6]. This device

allows us to define the management of watering, feeding and cleaning of a farm in the same enclosure with data storage in a MySQL database for the evolution of science. It is a tool for managing a farm from near or far and a decision-making tool, accessible to technicians and farmers, Aubry and Salaün [7]; The said Ifip farm, implemented in 2018, their watering system with a dosing pump allowing to have water permanently in the farm thanks to pipettes to ensure well-being by the absence of thirst, Ifip-Institut du porc [8]. Lely Vector's T4C automated feeding system provides reports that offer more information on feeding costs in relation to dairy and beef cattle production. It provides access to relevant and easy to understand information. Dairy and beef producers can better manage the feeding of their herd. Farmers can feed each animal according to its needs. This system allows them to excel in dairy or beef production, Lely [9]. The present observation on the development of livestock system management modules, allows us to see that they do not integrate watering, feeding and sanitation in a farm. The tedious and costly equipment used and the technologies developed for its construction and installation are obstacles to the use of these modules in developing countries. To this end, we will first install sensors that will ensure data collection and visual and audio communication with the farmer. We will then develop a web application to manage an animal farm. In today's world where almost everyone has a smartphone, a computer and an internet connection, it is becoming important to monitor one's activities in real time, to be able to control one's farm equipment (lighting, heating, feeding, nutrition, cleaning) and to consult the status of the farm via a computer or a mobile device for efficient performance, Schewe and Stuart [2]. It is a device that can control some of the basic functions of a farm in a simple way, using a web browser. It will be equipped with an uninterrupted power management system using a photovoltaic system aimed at improving the performance of the developed module, Bressan [10].

More specifically, this theme of automating watering, feeding, sanitation, as well as making data available on a tablet, smartphone or computer for analysis, in order to achieve better implementation of livestock farm strategies, can help boost the economy and solve the problem of hunger in developing countries. This automation has a threefold objective: first, to increase productivity by reducing the rate of contamination, which is a major difficulty for

livestock farmers. This contamination has an effect on production, prices and markets, FAO [11]; secondly, it aims to improve the living conditions of livestock farmers, given that farms are generally remote, inaccessible and the work is repetitive; thirdly, it aims to increase the use of renewable energy in the livestock system, given that our regions are often subject to very long power cuts.

## 2. METHODOLOGY

The management of the farm as we conceive it, is effectively done remotely using a "Global System for Mobile Communications" (GSM) module and a web application. The ultrasonic sensors (HC-SR04) installed will allow the collection of data and thus control the supply of water to the livestock available in the tanks at specific times. These ultrasonic sensors are installed above the tanks to control the amount of water available in the tanks and discharged into the troughs. The water flow is controlled by two solenoid valves at specific times: one to bring the drinking water from the tank to the trough and the other to lead the water to the water jet sanitation system. The feeding of the farm animals will be done by controlling the motor of a screw conveyor. A weight sensor (HX-711) is mounted on the platform below the conveyor to control the amount of feed discharged into the conveyor and available in the silo. The amount of water discharged is a function of the flow rate, the duration of the flow in the trough and the amount of feed discharged is a function of the weight of the feed and the duration of the flow. A "Real Time Clock" (RTC) module will therefore be installed for real-time management of the time, day, month and year automatically (duration). A Buzzer, an LCD screen, a SIM900 module for sending messages and a web application ensure sound and/or visual communication with the outside environment. The buzzer sounds and "Short Message Service" (SMS) is sent to the farmer in the event of a lack of water in the various tanks and a lack of feed in the silo; the LCD screen shows us in real time the exact time on the farm and the various quantities available. These SMS messages are also sent to the farmer at 5.45am to signal the cleaning of the farm, at 6am and 4pm to signal the distribution of water for irrigation and at 6.15am and 4.15pm to signal the distribution of food in the farm. Note that these sensors and actuators are connected

to the Arduino microcontroller module. The Ethernet Shield is embedded in the module and allows these data to be sent to the computer network according to a developed flowchart.

For this purpose, a web application is developed and implemented for communication via the internet and Global System for Mobile Communications (GSM). This application has a MySQL database to store the different quantities of water and feed available in the tanks and silo. The quantities discharged are also stored in this database. This database is hosted on an online server (<https://www.camoo.hosting>) under the domain name: [evinafarm.cm](https://www.evinafarm.cm). This data is displayed in real time by the web application. The history of the data stored in the database can be retrieved. In case of empty silos or tanks, a notification is displayed on the application; an email and an SMS are automatically sent to the farmer.

After the needs analysis of the web application, the following languages and software tools were used: HyperText Markup Language (HTML), the language behind our web application, which works with tags. It is used to represent the structure of our web pages. It allows you to write the content of your web pages and to structure them; Cascading Style Sheets (CSS): this is the formatting language of our web application. Used to apply style to the elements of the web page, it handles colour choices, menu sizes and more; JAVA SCRIPT: This is a client-side scripting language that handles the front-end used to create the interactivity and logic of the web pages; PHP: This allows for the administration of our web application and handles the back-end of our application by facilitating communication with the server. It also allows us to connect to the MySQL database; Structured Query Language (SQL): used to write the queries executed by the database management system, it is a computer language used to operate databases. It allows in a general way the definition, the manipulation and the security control of our data; ASTAH PROFESSIONAL: modelling tools "Unified Modeling Language" (UML) used for the realization of modelling diagrams; Visual Studio Code: is an extensible code editor developed for the writing of codes of realization of the web application and an Arduino IDE: This is an integrated development environment used for writing lines of code for the Arduino module.

## 2.1 Implementation of the Prototype in a Global Network

The principle used is almost identical to that developed by Tangka and *al* in 2021. A logic flowchart was developed for the programming, as shown in Fig. 3. The various inputs were then coded and integrated into the program. The program was then written and fed into the Arduino microcontroller and built using the ISIS PROTEUS software flowchart, as described in the papers by Cathleen and Gordon [12], Christian [13].

Knowing that a computer network refers to a set of computers and terminals interconnected to exchange digital information, the Ethernet Shield module is mounted on the Arduino module and connected to a router to ensure the sending of sensor data (ultrasound and weight) into the internet network. Several computers, tablets and smartphones can be connected according to Audibert [14] in his paper. Therefore, the flowchart of the connection of the Arduino module to the internet network (Fig. 1) is developed. When programming the Arduino module, we specified the IP address of the server computer and the Ethernet Shield while routing the packets using the D-Link router. The router is responsible for directing the packet traffic through the network. Thus, all the "packets" collected by the sensors connected to the Arduino module will be directed into the web

application database and displayed on the developed web application.

Fig. 2 illustrates the construction of the various component assemblies and connections of the module on a printed circuit board. These components are connected to a printed circuit board. It consists of an Arduino Mega board, three ultrasonic sensors, a DS1307 real-time clock (RTC), a card module for data storage (SD), a sim900 mini v3 module, three relay modules, a display (LCD) for visual monitoring of events, an Ethernet Shield module for sending data into the network and an electronic board. The assembly of the components was consistent with that described in the papers by Thomas et al [15] and Cathleen and Gordon [16].

The components are connected to an electronic board. We can note that the electronic board is developed using a copper plate on one side, alcohol, acetone, water, iron perchloride, the electronic circuit diagram, glossy paper and a laser printer. The electronic circuit diagram is obtained using the ARES platform of the ISIS Proteus software, Addax-electronics [17]. This involves transferring the circuit onto the copper plate. After obtaining the electronic board, we proceed to connect the different components.

Fig. 3 shows the flowchart of the developed web module. Its structure is used by the program introduced in the Arduino module.

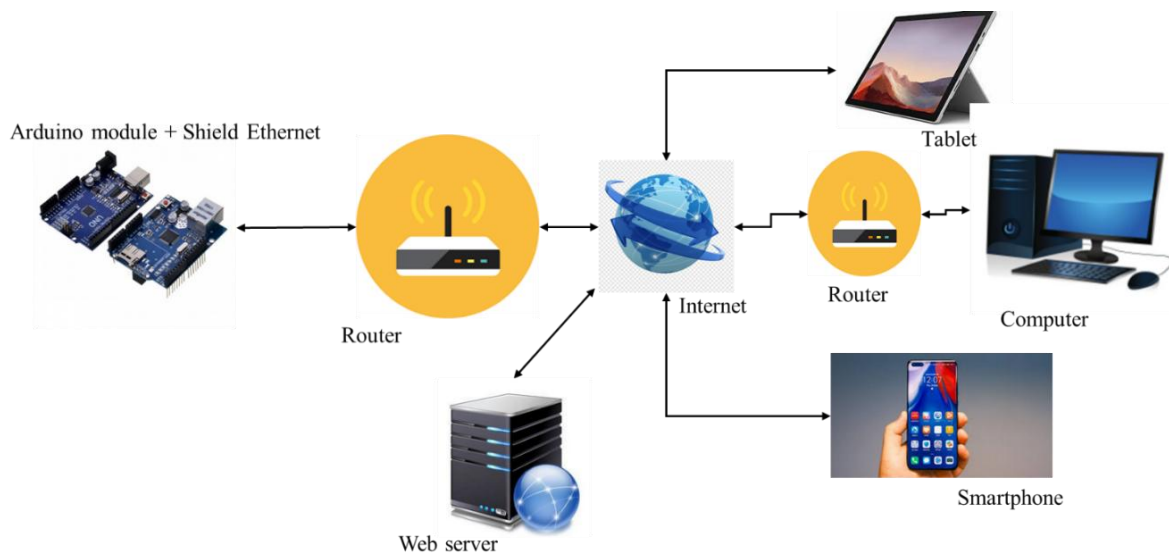
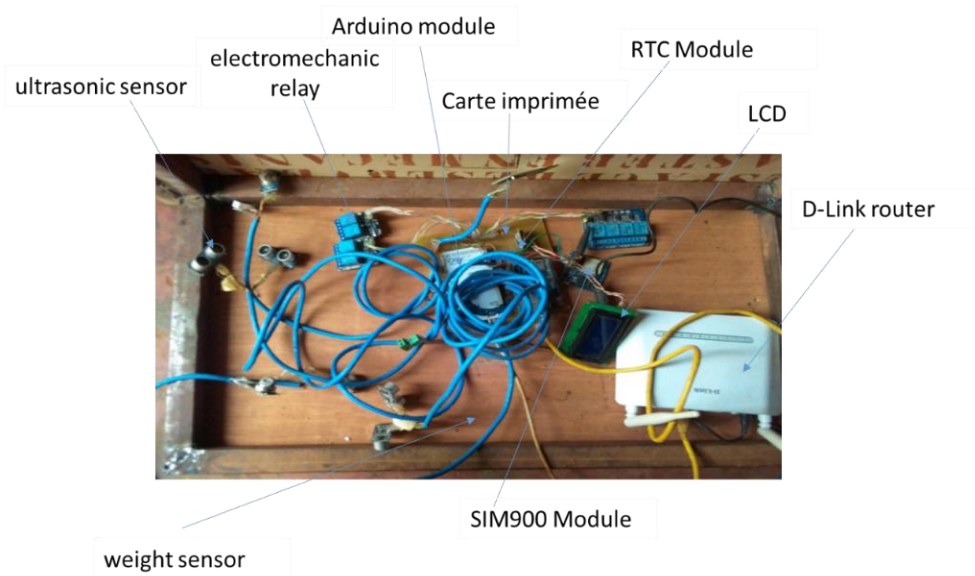

Fig. 1. Connection of the Arduino module to the internet network



**Fig. 2. Connection of the components of the web application of the automatic management module of an animal farm to a printed circuit**

The diagram in Fig. 3 illustrates the flow chart of the web module for automatic management of watering, feeding and cleaning of an animal farm. It is a schematic representation of the functional, organisational links to control the watering, feeding and cleaning of a livestock farm on the one hand, and to ensure efficient communication with the farmer on the other, Hadley [18]. We initially perform declarations of the SD card, GSM, RTC, LCD\_I2C and Ethernet Shield libraries, followed by the initialization of the Arduino board's input and output ports, which are communication support connectors. We then check the amount of water in the drinking water silo, the amount of feed in the tank and the amount of water in the cleaning water silo. The time of watering, feeding and cleaning is controlled and executed depending on the type of farm. Note that: watering is done here at 5.45am and 3.45pm; feeding is done at 6.00am and 4.00pm and cleaning at 5.15am. If these time conditions are met, the subroutine for watering, feeding and cleaning respectively is executed. Similarly, the subroutines for sending data to the web application database and for communicating with the farmer remotely by call and SMS are executed. A visual signalling by means of an LED is performed. In case of lack of water or feed, the call and SMS subroutine is executed.

Fig. 4 illustrates the overall use case diagram of the management of a connected farm. This use case diagram in the figure below presents a discrete unit of interaction between a user (human or machine) and a system (animal farm). It is the overall use case diagram of our automated animal farm management system, a static view of the functional behaviour of the system, Longuet [19]. The description of the use cases clarifies the flow of the functionality, and describes the chronology of the actions that will have to be performed. It describes the main functions of the system from the point of view of the actors (Arduino module plus Ethernet Shield, user and administrator). This diagram illustrates the structure of the main functions required:

- Ensuring the authentication of the various users of the system;
- Acquire and provide information about the module and the type of farm;
- Acquire data on physical quantities measured with the help of ultrasonic sensors (HC SR04) and mass measurement sensors (HX 711);
- To allow consultation of the data;
- Control watering, feeding, cleaning;
- Manage user accounts;
- Collect and visualise the data collected.

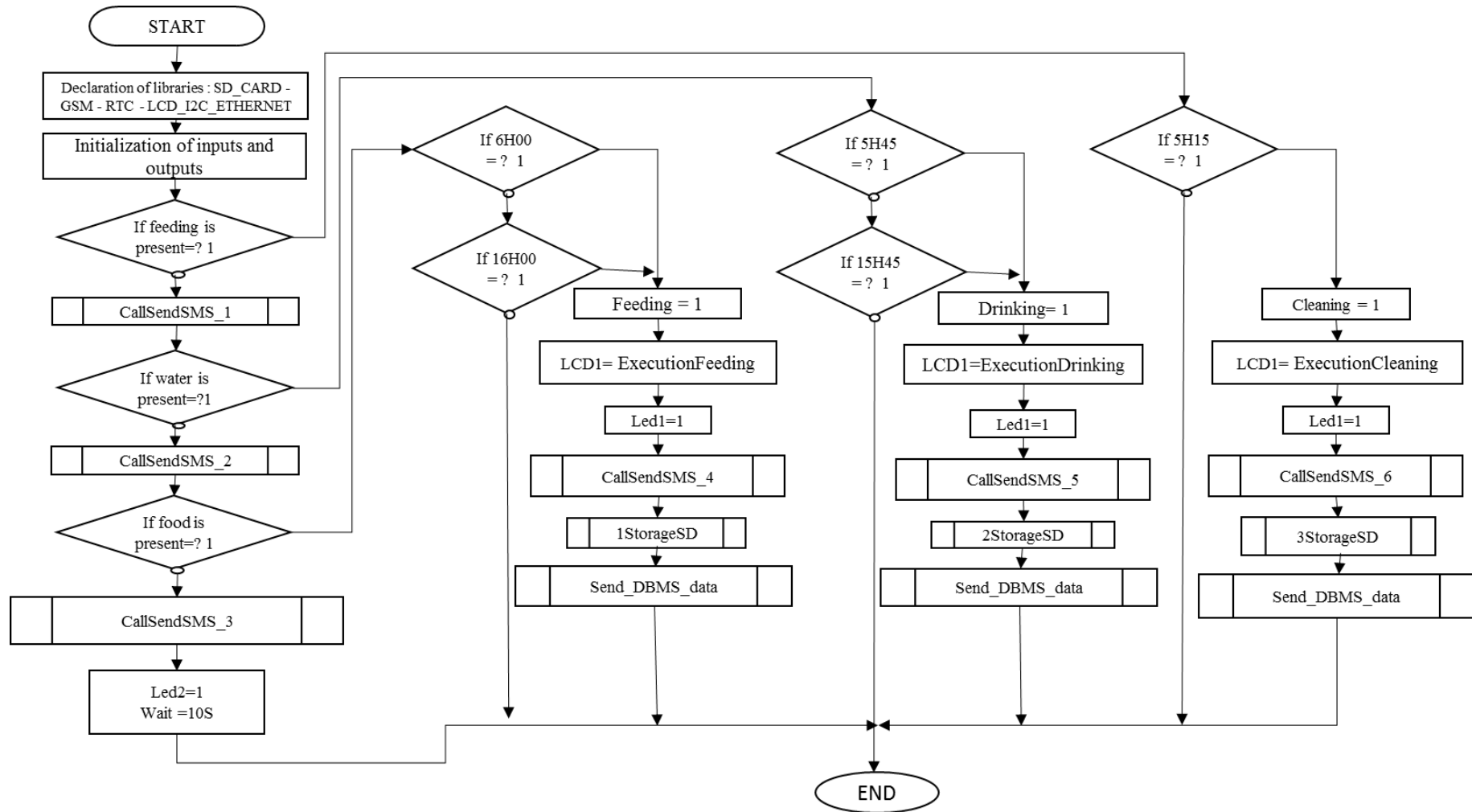

Fig. 3. Flowchart of the automatic farm management web module

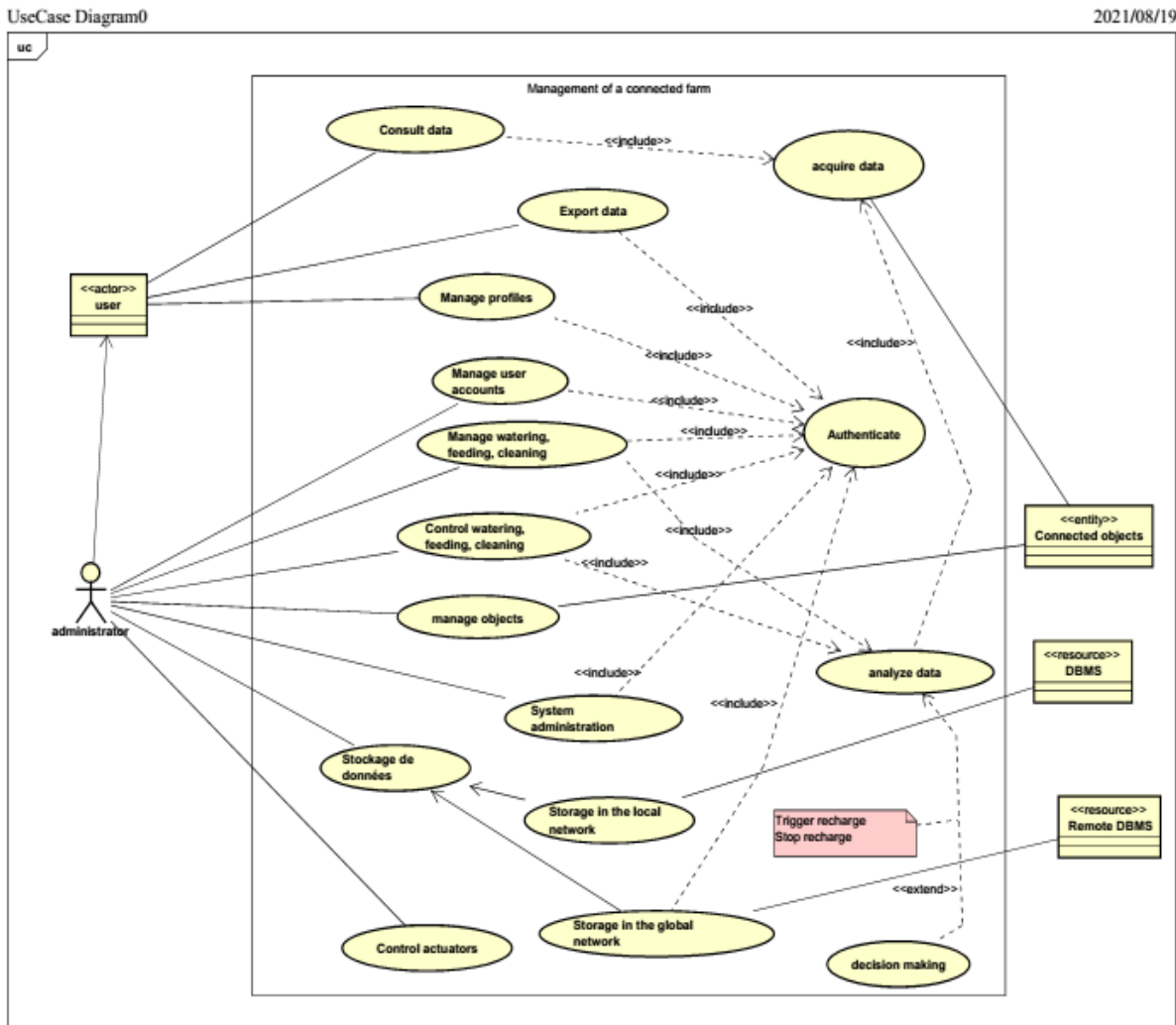

Fig. 4. Diagramme de cas d'utilisation global: Gestion d'une ferme connectée

## 2.2 Development of the Electric Power Management System

The development of a web-based automatic farm management module must work continuously, using solar energy to power the various devices. It must have a three-day autonomy. Standard PV GIS sizing techniques and solar data at the geographical coordinates of Dschang in Cameroon (from the NASA data centre [20], 5° 27' 0" North, 10° 4' 0" East) were used to determine the solar installation needed to run the appropriate inverters and charge controllers, Tangka et al. [5].

The uninterrupted energy of our module is thus obtained by means of a photovoltaic system dimensioned and designed using solar panels which are complete generators of electricity

when placed in solar radiation, a battery for storing electric current thus ensuring the desired autonomy, a charge controller to ensure proper control of the charge and discharge of the battery, electrical conductors, connection dominoes, and protective devices, Djenidi [21]. The following steps have been considered for the design of a photovoltaic system:

### • Step 1

Step 1 focuses on determining the energy requirements of the module, Marc et al. [22]. It consists of a power inventory of the installed equipment followed by the evaluation of the average daily operating time and finally the determination of the total daily energy requirement. Expressed in (Wh/d). It will be calculated by formula 2.1.



$$E_{ct} = \sum_{i=0}^n P_i t_{f_i} \tag{2.1}$$

With:

- $E_{ct}$  : Total daily energy in Wh/d;
- $P_i$  : Power of a given equipment in W;
- $t_{f_i}$  : Daily number of hours of operation of the given equipment in h;

• **Step 2**

This step consists of the optimisation of the system energy demand and the re-evaluation of the electrical energy demand, Lazaar [23]. The determination of the forecast power (Pp) and the forecast daily energy (Ejcp) with a forecast coefficient (Kp ) of 1.2 in direct current (DC) is performed.

$$P_p = P_c K_p \tag{2.2}$$

$$E_{jcp} = P_c t_f K_p \tag{2.3}$$

Avec:

- $P_p$  : The predicted power in W;
- $E_{jcp}$  : The forecast daily energy consumed in Wh/d;
- $P_c$  : The power consumed by the equipment in W;
- $t_f$  : Daily number of hours of operation of the equipment in h;
- $K_p$  : The forecast coefficient.

• **Step 3**

This is the determination of the size of the batteries: It consists in the determination of the capacity Qt in Ah of the batteries according to the coefficient of recovery (Kr = 2) due to the charge and discharge of the batteries; the depth of

charge and discharge Kc which is a function of the type of batteries used (Kc=0.8 for lithium batteries and 0.4 for lead batteries); the number of days of autonomy here Ka= 3; the battery voltage V here 12v and the forecast daily energy consumed, Rekioua et al. [24].

$$Q_t = K_r K_c K_a \frac{E_{jcp}}{V} \tag{2.4}$$

• **Step 4**

Sizing of the solar panels: This is the determination of the photovoltaic field as a function of the photovoltaic grid voltage (V=12v); the number of equivalent hours of sunshine (Ne); the peak power (Pcp= 200Wp) of the chosen PV module; the number of solar modules required in parallel and the loss coefficient, PVGIS [25].

$$E = P_c C_p N_e \tag{2.5}$$

With:

- $P_{cp}$ = peak power of the photovoltaic field (Wp);
- $E$ = total daily load (Wh/d) still corresponds to  $E_{ct}$  ;
- $C_p$ = Loss coefficient (kWh/m<sup>2</sup>/d);
- $N_e$ = Number of hours of daily sunshine.

The loss coefficient Cp varies between 0.9 and 0.1, i.e. 10% to 90%. The most common value is between 0.72 and 0.8, i.e. 25% and 20%. But in our framework we consider 0.74.

• **Step 5**

This step consists of the determination of the charge controller: This consists of the determination of the power of the controller or the maximum current it can control for a given nominal voltage, PVGIS [25].

The characteristics of the photovoltaic device will take into account the elements in the table below.

**Table 1. Evaluation of the photovoltaic device of the web application module**

Designation	Characteristic
Power consumed per day in watts	71.12W
Number of operating hours (depending on the operating time of each equipment)	222h
Daily energy (Edc) consumed or daily load battery capacity	1591,71 Wh/j
installed peak power	397.93Ah
	774,53Wc



### 2.3 Determination of the Overall Cost of the Automatic Farm Management Module

The global cost of the module consists of a summary of the different materials used for the realisation of the module as defined by the research objective. The evaluation of the cost of the aforementioned web module for the automatic management of a livestock farm is carried out and illustrated by Table 1 in the appendix.

## 3. RESULTS AND DISCUSSION

### 3.1 Web Application for Automatic Animal Farm Management

The figures below illustrate the images of the platform of our automatic animal farm management application, accessible from a web browser via the address "www.evinafarm.cm". This open home page introduces us to the name and purpose of the application. We can then access the authentication control page by clicking on the login icon (Fig. 5). The authentication page allows us to enter our access information to the various farm data consultation pages using a login, in this case an email address and a password (Fig. 6). This password is assigned to the farm administrator. He can then add and delete users. After authentication, the different data consultation pages are accessed:

- The feed data consultation page allows the monitoring of the evolution of the quantity

of feed consumed and the quantity of feed available. It also allows the export of this data to an Excel file (Fig. 7);

- The page for consulting the watering data allows the control of the evolution of the quantity of water consumed and the quantity of water available. It also allows the export of this data to an Excel file (Fig. 8);
- The page for consulting the farm cleaning data allows the control of the evolution of the quantity of water consumed and the quantity of water available for cleaning. It also allows the export of these data in an Excel file (Fig. 9);
- The intervention page allows the administration of the operation. The main administrator can introduce other stakeholders that he considers important for the monitoring of his farm (Fig. 10).

### 3.2 Characteristic of the Photovoltaic System of the Web-based Module for Automatic Management of an Animal Farm

The power supply of the uninterrupted energy module has been developed and its characteristics are known (Table 2).

### 3.3 Estimated Cost of the Web Module for Automatic Animal Farm Management

The summary table of the quantitative and estimated cost of the web module for automatic management of an animal farm is presented in Table 3.

**Table 2. Evaluation of the photovoltaic system of the automatic web management module**

N°	Designation	Quantity	Characteristic
1	Solar panel	4	200Wc – 12V – Single crystal - Vitron
2	Battery	2	200Ah – 12V – Vitron Energy
3	Charge controller	1	100A – 12V - Vitron Energy - PWM
4	Connector	10	Flexible - multi colour
5	Dominoes	1	Strip - Ingelec
6	Junction box	2	Rigid - exposed - Ingelec
7	Protection fuse	1	100A – 12V
8	Distribution box	1	Ingelec - insulated

**Table 3. Summary table of the cost of the web module for automatic farm management**

N°	Designations	Total Price (FCFA)
1	Web device for automatic management of an animal farm	776000
2	Device for producing electrical energy	400000
Labour estimated at 30% of the cost of expenditure		352800
<b>Total</b>		<b>1528800</b>

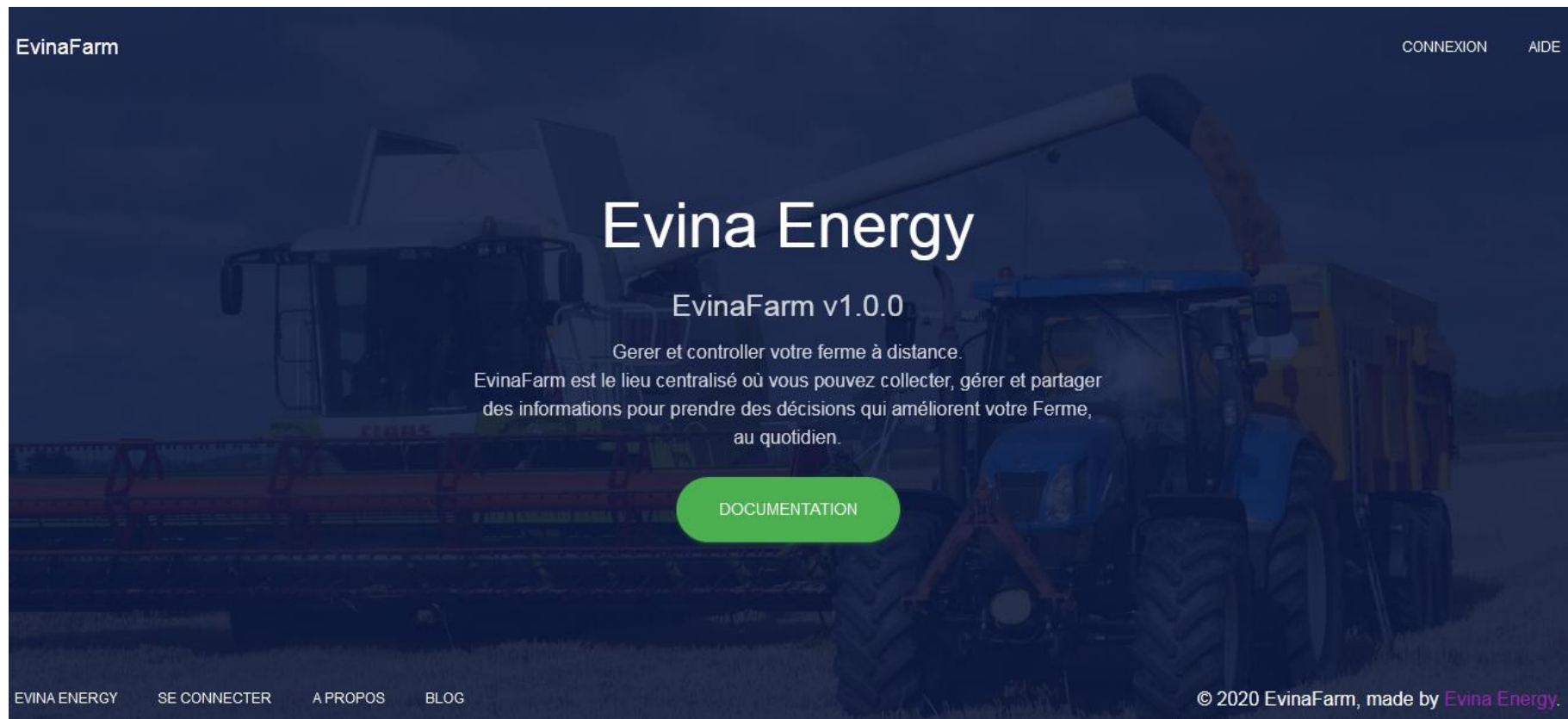

Fig. 5. Home page

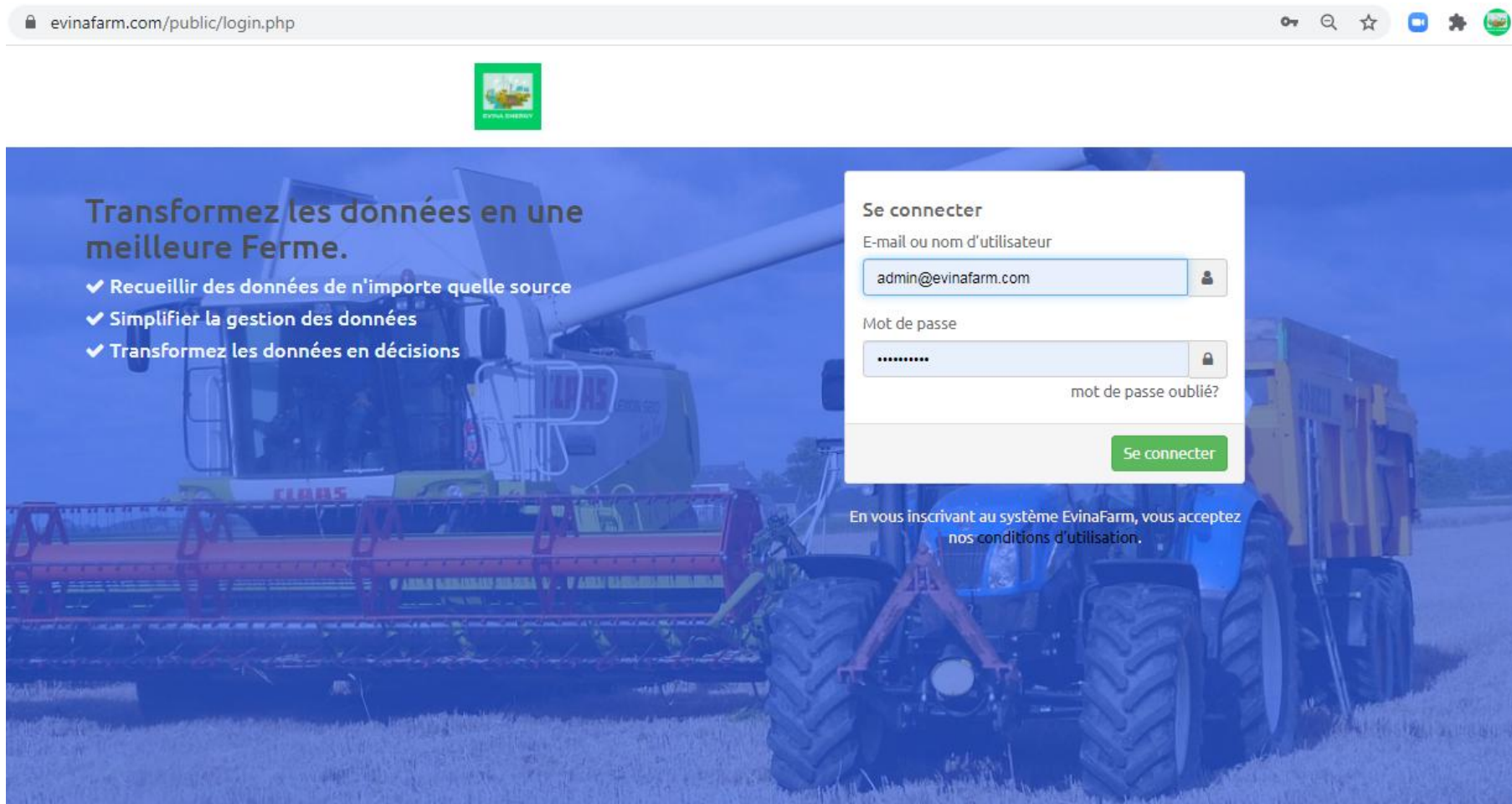

Fig. 6. Authentication page

The image shows a web dashboard for 'EVINAFAM'. On the left is a vertical navigation menu with icons and labels: 'Temperature', 'Ammoniac', 'Gaz Carbonique (CO2)', 'Humidité', 'Energie Electrique', 'Alimentation' (highlighted in green), 'Abreuvement', 'Nettoyage', and 'Intervention'. The main content area is titled 'Dashboard' and features a top navigation bar with 'ADMINISTRATION DE LA FERME', 'NOTIFICATION' (with a red '5' badge), and 'MON COMPTE'. A central white card displays 'Alimentation' data for 'Silos principal et secondaire': 'Qté Aliment consommé: 8 kg' and 'Qté Aliment disponible: 9 kg'. Below this is a blue button labeled 'EXPORTER LES DONNÉES AU FORMAT EXCEL'. At the bottom of the dashboard, there are links for 'EVINA ENERGY', 'A PROPOS', and 'BLOG', and a copyright notice: '© 2020, made by Evina Energy.'

Fig. 7. Feeding data consultation page

The screenshot shows the EVINAFAM dashboard interface. On the left is a sidebar with navigation items: Temperature, Ammoniac, Gaz Carbonique (CO2), Humidité, Energie Electrique, Alimentation, Abreuvement (highlighted in green), Nettoyage, and Intervention. The main dashboard area is titled 'Dashboard' and contains several components:

- Top right navigation: ADMINISTRATION DE LA FERME, NOTIFICATION (with a red '5' badge), and MON COMPTE.
- Abreuvement (Drinking) section: A green header with 'Abreuvement' and 'Quantité et controle'. Below it is a table:

Quantité d'eau consommé:	14 L
Quantité d'eau disponible:	4 L
- Historique (History) section: A white card with a green header 'Historique' and a green progress bar showing '43% Changement journalier'. Below the bar, it says 'mis à jour il ya 2h.'.
- EXPORTER LES DONNÉES AU FORMAT EXCEL button: A blue button located below the Abreuvement table.
- Footer: EVINA ENERGY, A PROPOS, BLOG, and © 2020, made by Evina Energy.

Fig. 8. Drinking data consultation page

The screenshot displays the EVINAFAM dashboard interface. On the left is a vertical navigation menu with the following items: Temperature, Ammoniac, Gaz Carbonique (CO2), Humidité, Energie Electrique, Alimentation, Abreuvement (highlighted in green), Nettoyage, and Intervention. The main dashboard area is titled "Dashboard" and includes a top navigation bar with "ADMINISTRATION DE LA FERME", "NOTIFICATION" (with a red notification bubble), and "MON COMPTE".

The dashboard features two primary data cards:

- Abreuvement** (Watering):
  - Section: Quantité et controle
  - Table:

Quantité d'eau consommé:	14 L
Quantité d'eau disponible:	4 L
- Historique** (History):
  - Section: 43% Changement journalier
  - Status: mis à jour il ya 2h.

Below these cards is a blue button labeled "EXPORTER LES DONNÉES AU FORMAT EXCEL". At the bottom of the dashboard, there are links for "EVINA ENERGY", "A PROPOS", and "BLOG", along with a copyright notice: "© 2020, made by Evina Energy."

Fig. 9. Cleaning data consultation page

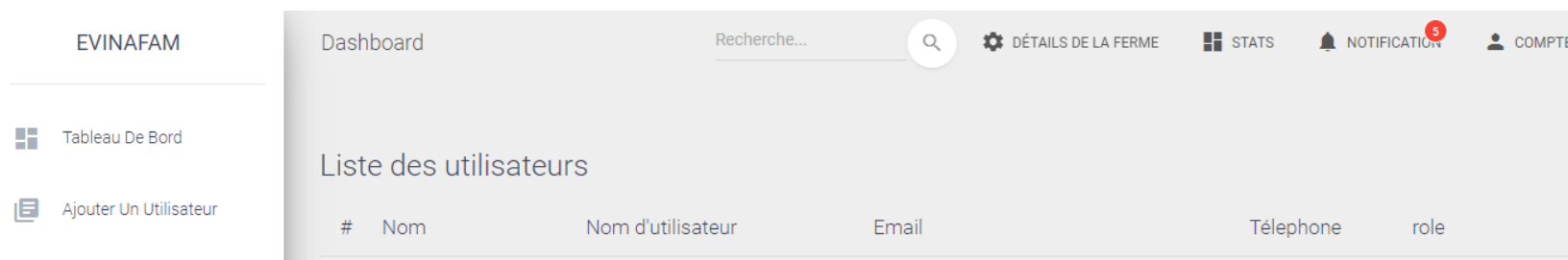

Fig. 10. Farm administration page

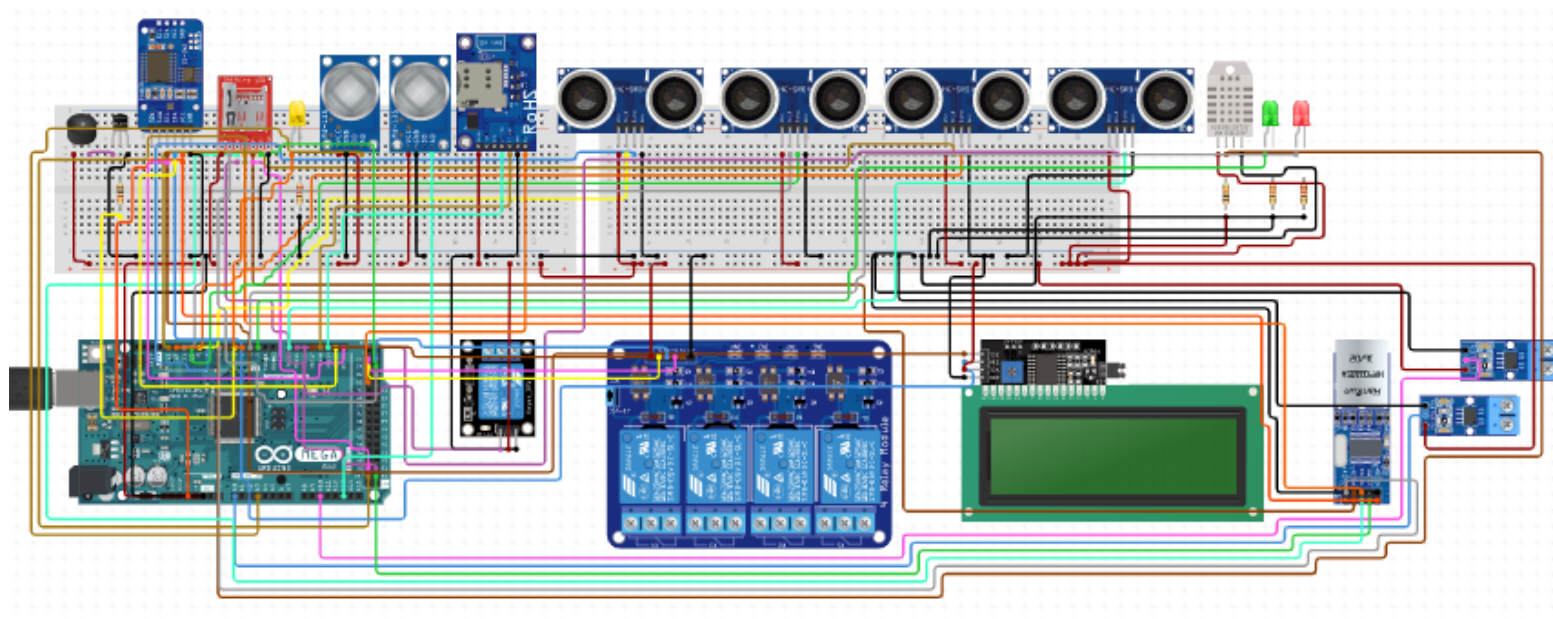

Fig. 11. Electronic diagram of the web module for the automatic management of a farm



The total estimated cost of the module takes into account not only the expenses for the realisation of the automatic management module but also the expenses for the realisation of the test prototype of a breeding farm. This cost of the module offers many advantages for the farmer. According to Nicolas Mérouze in his article in 2019 [26], The development of an application involves many variables that must be understood and controlled to control its budget. These are: All stages of development; Complexity of features; Numerous profiles of the development team; Expenses after release. Thus, the cost of the module is one million five hundred and twenty-eight thousand eight hundred francs (1528800FCFA). It is advantageous and economical for the user as the web application only consists of creating one or more links from the application to the web address of an Internet site (URL) and run inside the device's web browser via a simple, low-cost URL, Cherfioui and Messaoul [27]. The high cost comes from the photovoltaic system which allows a return on investment after 15 years depending on the price of the kWh of electrical energy and the price of the solar system equipment. Therefore, the developed web module is very advantageous in animal husbandry and can be popularised on a large scale.

### 3.4 Electronic Circuit of the Web Module for the Automatic Management of an Animal Farm

Fig. 11 shows the general electronic circuit diagram wired for the management of a connected farm according to our specifications.

### 3.5 Presentation of the Web Module for the Automatic Management of an Animal Farm

The presentation of the realised module (Fig. 12) is made. It allows us to visualise the module actually developed in the context of our article.

The web module for the automatic management of an animal farm developed houses the module's equipment. It is a prototype for the management of an animal farm via the Internet. At the end of our conception and realization of the said module, we can draw conclusions developed around the control of the technical resources of the stockbreeders and the difficulties met by the farmers in particular in rural environment.

### 3.6 Real Test of the Web Application for Automatic Management of an Animal Farm

The test was conducted in real time on a farm and in the laboratory of the agricultural engineering research unit. We observed the real test of the web-based automatic farm management module in the laboratory of the agricultural engineering research unit under a local network (Table 4).

Initial testing of the prototype revealed a minimum efficiency of 83.33% for all units. Field and laboratory tests indicated that the module is able to communicate with the farmer within 1-2 seconds of completing each task. It was concluded that the use of this module can seriously reduce the number of visits to the farms, thus reducing the drudgery of the work and the possibility of spreading diseases.

The web application for automatic animal farm management, "evinafarm", is launched from the traditional web browser such as Google Chrome. It provides real time information about our animal farm. This application is a software, without the need for installation and hosting, thus offering the possibility for one or more farmers to use it. It is accessible via a computer or a smartphone. This application requires electronic components to obtain the data.

The electronic scheme that facilitates the sending of data to the global network database, via the sensors, is developed (Fig. 11). The data of available and consumed (discharged) amount of drinking water, feed and cleaning water, using the components such as: Arduino Mega; Ethernet shield; LCD - I2c; LED; ACS712; HX711; HC-SR04; Relay module, as mentioned earlier, are communicated and stored in the MySQL database in real time.

After designing the application, we developed its automatic management platform, accessible from a web browser. An effective laboratory test under a global network is performed as shown in Table 4 with excellent results. We can thus say that this device allows the management in the same enclosure, of watering, feeding and cleaning of a farm with conservation of information for the evolution of science in a database, available to any farmer, introduced according to the rules to the network. This module, through the management via the web application, adds to the module developed in the article by Tangka et al in 2021 [5].



Fig. 12. Web module for automatic animal farm management

Table 4. Real test of the web-based module for automatic management of an animal farm

N°	Test of the application under global network	Results	Observation
1	Time in the farm	10h15min	/
2	Time for displaying the quantity of water in the watering tank	Almost instantaneously every one minute	Data instantly transmitted to the web application
3	Time for displaying the amount of water discharged	Almost instantaneously every one minute	Data instantly transmitted to the web application
4	Duration for displaying the quantity of water in the watering tank	Almost instantaneously every one minute	Data instantly transmitted to the web application
5	Time for displaying the amount of feed dumped	Almost instantaneously every one minute	Data instantly transmitted to the web application
6	Time for displaying the amount of water in the cleaning tank	Almost instantaneously every one minute	Data instantly transmitted to the web application
7	Time for displaying the amount of cleaning water discharged	Almost instantaneously every one minute	Data instantly transmitted to the web application

#### 4. CONCLUSION

Taking into account the objectives set, the methodology adopted and the results obtained, the following conclusions can be drawn:

- The device for automating the watering management of a solar powered animal farm has been designed and implemented. This device, which has considerable flexibility thanks to its programme that depends on the farmer's specifications, has contributed effectively to solving the problem posed by farmers in rural areas, despite the 1-2 second delay in transmitting the instruction signals due to the quality of the equipment used for its

implementation. It ensures the watering of animals at fixed times while transmitting the quantities available and consumed by the animals;

- The Solar Farm Animal Feeding Automation System has been designed to effectively control the feeding of animals at precise times with excellent communication with the farmer via GSM and web application. It also ensures the transmission of the quantities of feed available and consumed by the animals. It is as flexible as watering according to the specifications set by the farmer. It has effectively contributed to solving the problems highlighted by farmers despite the 1-2 second delay in the transmission of

- control signals due to the quality of the equipment used for its implementation;
- A web application for the automatic management of a solar farm was designed and implemented, ensuring perfect real-time communication with the farmer via a local network or the internet, and saving the data in a MySQL database. This device, which can be adapted to the specifications of the type of farm, ensures the management of watering, feeding and perfect communication with the farmer. It has a response time for the transmission of control signals of 2 to 3 seconds thanks to the quality of the equipment used for its construction;
  - The total estimated cost of the module is one million five hundred and twenty-eight thousand eight hundred (1528800FCFA). This evaluation takes into account not only the expenses for the realization of the automatic management module but also those for the realization of the test prototype in a breeding farm. This means that the developed web module is very advantageous for animal husbandry and can be widely disseminated.

The first tests of the prototype revealed a minimum efficiency of 83.33% for all units. Field and laboratory tests indicated that the module is capable of communicating with the farmer within 1-3 seconds after each task is performed. It was concluded that the use of this module can seriously reduce the number of visits to the farms, thus reducing the drudgery of the work and the possibility of spreading diseases. In the same vein, it is a tool for the management of an animal farm and a decision support tool, Aubry and Salaün [7]. The work carried out in this area can be extended into the field of animal and farmer safety on the one hand, and adaptation to different farms on the other.

## COMPETING INTERESTS

Authors have declared that no competing interests exist.

## REFERENCES

1. MINEPIA (Ministry of Livestock, Fisheries and Animal Industries), 2017. Livestock Development Project. Yaoundé, Cameroon: MINADER. 2015;23. Also available on accessed June 12, 2017.
2. Schewe RL, Stuart D. Diversity in agricultural technology adoption: How are automatic milking systems used and to what end? *Agric. Human Values*. 2015;32. Available: <https://link.springer.com/article/10.1007/s10460-014-9542-2>.
3. Roels C. *Beginning software analysis with UML*. Paris, France; 2016. Available: <https://openclassrooms.com/fr/courses/2035826-debutez-lanalyse-logicielle-avec-uml/2035851-uml-c-est-quoi>. [Accessed 23 May 2020].
4. Landais E, Weisslinger H. *Principles of syion modelling in computer networks*. Bordeaux, France: EISTI. 1992;342.
5. Tangka JK, Evina NWM, Ngah JN. Development of a Computerized Automated System. *Current Journal of Applied Science and Technology*, (CCAST). 2021;15. DOI: 10.9734/CCAST/2021/v40i331279, 15pp. Available: <https://journalccast.com/index.php/CCAST/article/view/31279>.
6. IFIP. Bilan d'activité 2017. Paris, France: IFIP-Institut du porc. 2017;120. Available: <https://www.ifip.asso.fr/sites/default/files/pdf-documentations/bilan-activite-ifip-2017.pdf>.
7. Aubry A, Salaün Y. A new tool for investment decision support in pig farming. *Journées Recherche Porcine*. 2017;49. Available: <https://ifip.asso.fr/sites/default/files/pdf-documentations/es9.pdf>
8. IFIP. Technical results of organic pig farms in France. Paris, France: Paris, France: IFIP-Institut du porc. 2018;8.
9. Lely HNV. A new stage in automated feeding. Maassluis, The Netherlands; 2017. Available: <http://www.agriavis.com/news-7114-lesystem-of-management+lely+t4c+connects+the+new+system+of+automated+feeding+lely+vector+t+the+processing+system+astronaut.html>.
10. Bressan M. Development of a supervision and control tool for a solar photovoltaic installation. HAL Id: tel-01068025Paris, France: CCSD. 2014;160.
11. FAO. *Livestock in the World 2011: Contribution of livestock to food security*. Rome, Italy: FAO. 2011;12.
12. Cathleen S, Gordon M. *Electronics for dummies*. The principle of practical electronics [Electronics for dummies. The

- principle of practical electronics]. Paris, France: FIRST Interactive. 2014;437.
13. Christian D. Major 8-bit microcontroller founders. *Microcontroller Systems*. Saint-Étienne, France [Main founders of 8-bit microcontrollers. *Microcontroller Systems*]: Ecole Nationale Supérieure des Mines. 2008;16.
  14. Audibert L. *UML 2 of practical learning. Introduction to object modeling*. Paris, France; 2013.  
Accessed on 22/05/2020  
Available: <https://laurent-audibert.developpez.com/Cours-UML>.
  15. Thomas EM, Hien D, Caitlin W. *Introduction to the arduino microcontroller. Hands-on Research in Complex Systems*. Shanghai Jiao Tong, China: University of Shanghai Jiao Tong. 2012;6.
  16. Cathleen S, Gordon M. *Electronics for dummies. The principle of practical electronics*. Paris, France: FIRST Interactive. 2014;437.
  17. Addax-Electronique. *The steps in the manufacture of an electronic board*; 2021.  
Accessed on 17/08/2021  
Available: <https://www.addax-electronique.com/etapes-fabrication-carte-electronique.html>.
  18. Hadley MJ. *Web Application Description Language*. SMLI TR-2006-153 Published March 2006.  
Available: <https://dl.acm.org/doi/pdf/10.5555/5/1698142>.  
[Accessed on 15 March 2020].
  19. Longet D. *UML Course 1: Introduction to software engineering and modeling*. Paris, Cameroon: Polytech Paris-Sud 3e année. 2018;52.
  20. NASA. *Climatology Resource for Agro climatology - Global coverage on a 1° latitude by 1° longitude grid*. National Aeronautics and Space Administration. *Prediction of worldwide energy resource*; 2021.  
Accessed on 12/01/2021.
  21. Djenidi K. *Study of a stand-alone photovoltaic system*. Algiers, Algeria: FST. 2015;8.  
Available: <http://archives.univ-biskra.dz/handle/123456789/6480>.
  22. Marc O, Dedriche E, Martin JF, Cocq TL, Castaing-Lasvignottes J. *Experimental determination of performance indicators for individual air conditioning systems in controlled environments*; 2020;16.  
DOI:10.25855/SFT2020-016, Belfort, France: UNIV-REUNION,  
Available: <https://hal.univ-reunion.fr/hal-03270962>.
  23. Lazaar N. *Optimisation of power supplies for data centres*. 2021NORMC206. Cherbourg, France: Laboratoire Universitaire des Sciences Appliquées de Cherbourg (LUSAC). 2021;120.  
Available: <https://tel.archives-ouvertes.fr/tel-03176623>.
  24. Rekioua D, Mehdioui T, Mansouri K, Taguelmimt S. *Technical and economic study of a solar photovoltaic/solar thermal system: Application to Bejaia (Algeria)*. *International Journal of Control, Energy and Electrical Engineering (CEEE)*. 2008;6:7.  
ISSN: 2356-5608.
  25. PVGIS. *How to size a photovoltaic system?* 2021.  
Available: <https://photovoltaique-energie.fr/dimensionner-un-systeme-photovoltaique.html>.
  26. Merouze N. *How much does it cost to develop an application?* synbioz; 2019.  
Available: <https://www.synbioz.com/blog/cout-developpement-application-web>.
  27. Cherfioui H, Messaoul H. *Design and realization of a WEB application (JAVA EE) for the follow-up of collections by implementing a web service Case: ENIEM*. TIZI-OUZOU, Algeria: UMMTO. 2019; 110.  
Available: <https://dl.ummtto.dz/handle/ummtto/12336>

## APPENDIX

Table 1. Evaluation of the cost of the web module for the automatic management of a farm

N°	Désignation	Quantities	UP (FCFA)	TP (FCFA)
1	Web host	1ans	30000	30000
2	Local server	1	200000	200000
3	Electrical conductor	10	500	5000
4	Arduino board	1	10000	10000
5	Ethernet Shield	1	10000	10000
6	Rj45 cable	4	1500	6000
7	Network hubs	1	8000	8000
8	Switches	1	5000	5000
9	Router	1	25000	25000
10	Modem	1	55000	55000
11	Ultrasonic sensor	2	2500	5000
12	Ground sensor	1	5000	2500
13	Liquid Crystal display - I2C	1	4000	4000
14	LED	5	100	500
15	Drinking trough	1	5000	5000
16	Feeder	1	5000	5000
17	Screw conveyor	1	25000	25000
18	Engine	1	17500	17500
19	Trunking	5	1000	5000
20	Switches	2	300	600
21	connectors	2	1200	2400
22	USB connectors	1	3000	3000
23	Stabilized power supply	2	3000	6000
24	electric current extenders	2	2500	5000
25	Protection fuse	2	500	1000
26	Plywood	1	3500	3500
27	Sheet metal	1	4500	4500
28	Angle iron	4	4000	16000
29	Rust protection	1	5000	5000
30	Paint	1	6000	6000
31	Angle Aluminium	5	4000	20000
32	Flat iron	3	3000	9000
33	Rivets	1	5000	5000
34	Welding rod	2	5000	5000
35	Male connectors	50	100	5000
36	Female connectors	50	100	5000
37	Box	1	2500	2500
38	Development of the web application	1	200000	200000
39	Solar panel	1	200000	200000
40	Battery	1	150000	150000
41	Charge controller	1	25000	25000
42	Connector	10	1000	10000
43	dominoes	1	2500	2500
44	Junction box	2	3000	6000
45	Protection fuse	1	1500	1500
46	Distribution box	1	5000	5000
<b>Total</b>				<b>1176000</b>

© 2021 EVINA et al.; This is an Open Access article distributed under the terms of the Creative Commons Attribution License (<http://creativecommons.org/licenses/by/4.0>), which permits unrestricted use, distribution, and reproduction in any medium, provided the original work is properly cited.

Peer-review history:

The peer review history for this paper can be accessed here:

<https://www.sdiarticle4.com/review-history/72490>