



Performance Evaluation of Tractor Operated Cotton Stalk Shredder Cum Uprooter

Srinidhi G. ^{a++*}, Sushilendra ^{a++}, Sunil Shirwal ^{a++}
and Vijayakumar Palled ^b

^a Department of Farm Machinery and Power Engineering, Central institute of Agricultural Engineering, Bhopal, MP, India.

^b Department of Farm Machinery and Power Engineering, College of Agricultural Engineering, Raichur, Karnataka, India.

Authors' contributions

This work was carried out in collaboration among all authors. All authors read and approved the final manuscript.

Article Information

DOI: 10.9734/IJECC/2023/v13i113499

Open Peer Review History:

This journal follows the Advanced Open Peer Review policy. Identity of the Reviewers, Editor(s) and additional Reviewers, peer review comments, different versions of the manuscript, comments of the editors, etc are available here: <https://www.sdiarticle5.com/review-history/108668>

Original Research Article

Received: 06/09/2023

Accepted: 12/11/2023

Published: 17/11/2023

ABSTRACT

A large amount of cotton stalk is generated in India every year. Cotton stalks are burned in the fields as crop residues due to a labour shortage and high investment costs. Global warming will be caused by burning the agricultural residues in the field and also by the loss of nutrients in the stalk. Cotton residue management is thus the best solution. To shred the cotton stalk into pieces and uproot the stubble left in the field, a cotton stalk shredder and cum uprooter are used. A performance study was conducted in the cotton field. The purpose of the experiment was to assess the performance of a cotton stalk shredder cum uprooter. The performance parameters considered for the study were uprooting efficiency, power requirement, draft requirement and fuel consumption with respect to type of uprooter blade, viz., cross, sweep and curved and rake angle viz., 10°, 20°

⁺⁺ Ph.D. Scholar;

*Corresponding author: E-mail: reddysrinidhi91997@gmail.com;

and 30°. The best results were observed for curved blade at a rake angle of 10°. The draft, power requirement, fuel consumption and uprooting efficiency were found to be 1.78 kN, 1.48 kW, 2.38 l h⁻¹ and 99.6 per cent, respectively.

Keywords: Cotton stalk shredder cum uprooter; draft requirement; power requirement; uprooting efficiency.

1. INTRODUCTION

Cotton is grown commercially over 111 countries throughout world. India stands second place in cotton production. The global area under cotton cultivation is 33.2 Mha accounting for 18.9 Mt of cotton [1]. The share of cotton in world textile production is 45 per cent and its production, processing and marketing sustains more than 250 million population. Cotton is one of the main source of India's economic growth and a foreign exchange earner. In India, cotton is majorly cultivated under rainfed conditions. The area of cotton cultivation in India is about 124.44 Mha with a production potential of 370 lakhs of bales [1]. Cotton plays a major role in Indian economy and offers employment for more than 60 million people. Cotton stalk is left over the field and it is treated as an agricultural waste which is available in large quantities. Cotton stalk contains about 68 per cent cellulose, 26 per cent lignin and 7 per cent ash. Cotton stalks possess fiber dimension comparable to most commonly available species of hardwood. It can therefore be used for the manufacture of particleboards, preparation of pulp and paper, hard board, corrugated boards, boxes and as a source of cellulose for the manufacture of microcrystalline cellulose. Cotton stalks can also be used to grow edible oyster mushrooms [2,3].

In India about 46 Mt of surplus residue of cotton is generated every year [4]. Most of the stalk produced is treated as waste though a part of it is used as fuel by rural masses. The bulk of the stalk is burnt off in the field after the harvest of crop. One of the difficulties in cotton cultivation is to clear crop residues after cotton harvesting. Normally, the plants are removed either by manual pulling or by cutting with sickle up to a height of 50 to 70 mm above ground and burnt later. The level of farm mechanization level in India stands at about 40-45 per cent with states such as UP, Haryana and Punjab having very high mechanization levels. North-eastern states are having negligible mechanization. This level of farm mechanization is still low as compared to the countries such as the U. S. (95 %), Brazil (75 %) and China (57 %). Even though the level of

mechanization in india lags behind other developed countries, it has seen an average agriculture growth rate of 3.56 per cent during last decade.

According to economic survey, farm mechanization and crop productivity have a direct correlation as farm mechanization saves time and labor, reduces drudgery, cut down production cost in the long run, reduces postharvest losses, boosts crop output and farm income. Use of improved implements has great potential to increase productivity up to 30 per cent and reduce the cost of cultivation up to 20 per cent. At present, Indian farmers adopt farm mechanization at a faster rate in comparison to recent past [1]. In Cotton cultivation, stalks are collected manual by labour and are put on fire. Manually clearing crop stalks from field requires 10 women worker per hectare to pull out/cut stalks, gathering, allowing to dry and then burning. Alternative for such problem is use of modern farm machinery like cotton stalk shredder cum uprooter. Shredder can shred crop stalks easily with coverage of an 1 hectare in 2.54 hour. Shredded crop can be spread in field or can be collected and become rich bio mass resource for agricultural and industrial usage. It can also become good organic manure by spreading in the field. Uprooter will uproot the cotton stubble left over the field after shredding by single pass. Incorporation of shredded cotton stalk and stubbles in to the soil increases the fertility of soil.

Several studies have been conducted to investigate the energy requirements, cutting efficiency, and other factors related to forage harvesters and uprooting equipment. Tribelhorn and Smith [5] found that increasing the knife velocity with constant cylinder diameter increased all cutter head energy requirements. Rider and Barr [6] reported that changing the number of cutter head knives and speed could alter the length of cut, while Persson [7] observed that cutting speed increases power loss due to material acceleration. Visvanathan et al. [8] determined that the minimum cutting energy was observed at a velocity of 2.5 m/s. For

cotton stalks, Pasikatan et al. [9] found that the best setting was 1050 RPM at 2 mm clearance, with 1062 kg/h capacity and 1.697 kWh/t specific energy. Chattopadhyay and Pandey [10] observed that when cutting speed was increased from 20 to 60 m/s, the cutting energy per unit cross-sectional area also increased. Gangade et al. [11] conducted a study on plant removing/uprooting efficiency for tractor-operated uprooters and found that the efficiency was 80%. Solanki and Yadav [12] reported that the curved blade had higher uprooting efficiency of 87.6% and a field efficiency of 0.143 ha/h as compared to other blade shapes. Senthilkumar et al. [13] found that increasing the number of blades and peripheral velocity resulted in a decrease in the length of cut. Suliman et al. [14] determined that the minimum fuel consumption rate for cotton stalk was 2.48 L/h. Alaa et al. [15] conducted a study that showed cutting drums clearance, chopper peripheral speed, number of plan blades on shredder, and kinematic parameters can affect the uprooting efficiency, with a moisture content of 10.46% and a cutting drum clearance of 2 cm resulting in a 28.87% efficiency.

2. MATERIALS AND METHODS

The performance evaluation was carried out in the research field at CAE, Raichur. The independent variables selected for study were at three levels as per the factorial CRBD experimental design and a total number of 27 experiments were carried out. The experiments were conducted in random order. To calculate error between the responses and independent variables, experiments were replicated thrice.

2.1 Design Refinement of Cotton Stalk Shredder Cum Uprooter

In India, cotton stalk is removed manually by using sickle or commercial rotavator and cross blade are used for uprooting the cotton stalk. The height of cotton plant varies from 1500 to 1800 mm. Plant to plant and row to row spacing of BT cotton is 600 and 900 mm. In traditional practices, cotton plant is burnt in the field which leads to release of green house gases and cause air pollution. Hence, there is a need for developing a machine for shredding and uprooting of cotton stalk. The refinement and development of cotton stalk shredder cum uprooter to make it suitable for cotton grown in this region was carried out. The required design refinement was carried out for components like tine and uprooter blade was considered in the

performance study. There are two functional components of cotton stalk shredder cum uprooter namely shredding and uprooting unit. The shredding unit consists of conveying section which conveys the cotton stalk to shredding section after cutting the stalk at base just above the ground. Shredding unit cut the cotton stalk into small pieces and throws the shredded cotton stalk through outlet. Uprooter will uproot the stubble left over in the field.

In order to get better performance from cotton stalk shredder cum uprooter, the relative motion between different working components is more important. For proper gathering and conveying of cotton stalk towards the shredding unit, the speed of shredding unit should be more than that of PTO speed. The diameter of shredding unit should be selected according to crop parameters. In order to have proper cutting action, the speed of shredding unit should be more than that of engine speed. If the shredding unit speed is too lower than required speed, it results in choking of shredding unit with crop materials. Higher machine forward speed at higher shredding unit speed with respect to machine forward speed results in uneven cutting and choking of shredding unit.

The machine forward speed depends on the crop density and its stalk moisture content at the time of shredding. The machine forward speed inversely proportional to the crop density and moisture content of plant stalks must be optimum for the crop under consideration. Too moist crop requires more energy to cut and results in uneven cutting. Optimum moisture content of plant stalks results in better shredding of cotton stalk. The speed of conveyor roller must be optimum for uniform feeding of crop to shredding unit. The front roller speed should be greater than the rear roller speed for better feeding of cut crop materials in to shredder assembly of cotton shredder. The feed rate of crop in to the shredding unit depends on the tractor forward speed.

The ultimate purpose of any shredding machine is to shred the crop with minimum length of cut without consuming much power. The shredder must have facilities for varying speeds of different working components like cutting unit speed, conveyor unit speed and shredding unit speed, depending upon the type of crop and field conditions. A suitable size of tractor should be selected to match the power and speed requirements of different working components of machine as the power requirement for conveyor

and shredding unit of different crops may vary with type of crop and its variety. Hence, an attempt has been made in this study to carry out the design refinement of working components of

cotton stalk shredder cum uprooter to match their crop material handling capacities and optimize their relative speeds and shredding of selected variety of cotton crop.

Table 1. Specifications of cotton stalk shredder cum uprooter used for the study

Sl. No	Components	Specification
1	Main frame	Fabricated from MS flat and MS angle
	Size of MS flat	65 × 15 mm
	Size of MS angle	40 × 40 × 6 mm
2	Converging	Fabricated from round mild steel bars and MS sheet
	Size of MS bar	15 φ mm
	Size of MS sheet	3 mm
3	Power transmission unit	Power is taken from PTO shaft and is transmitted to shredding plate and cutting and conveying unit. The power to the shredding plate was provided with the help of two sets of spur gears having teeth in the ratio 40:27 and 40:20. The power to the cutting and conveying unit was provided with the help of bevel and four spur gears.
4	Cutting and conveying unit	The cutting blade was made up of tungsten carbide. The conveying unit is made up from MS roller
	Size of blade	300 φ mm, 60 teeth on periphery
	Size of feeding rollers	225 φ × 190 mm
5	Shredding unit	It was made up of circular MS plate having provisions to bolt cutting knives
	Size of shredding unit	670 φ × 14 mm
	Diameter of shaft	50 φ mm
	Size of knives	335 × 80 × 5 mm
6	Uprooting unit	It was fabricated in the form of cross blade, sweep blade and curved blade. The width of all blade is 500 mm
	Size of cross blade	190 × 500 × 10 mm
	Size of sweep blade	85 × 500 × 10 mm
	Size of curved blade	100 × 500 × 10 mm
	Size of tine	600 × 40 × 40 mm

Table 2. Specifications of tractor used for the study

Sl. No.	Parameters	Description
1	Make	Mahindra ARJUN NOVO
2	Model	605 DI-i
3	Engine rated rpm	2100
4	Maximum PTO power, kW	37.5
5	Number of gears	15 F + 3 R
6	Travelling speed, km h ⁻¹	33.23
7	Lift capacity, kg	2200
8	Wheelbase, mm	2145
9	Length, mm	3660
10	Drive wheels	2 WD
	Type of tyres	Pneumatic and traction
	Size	Front 7.5-16 Rear 16.9-28
11	PTO speed, rpm	540

2.2 Development of Refined Components of Cotton Stalk Shredder Cum Uprooter

The essential components of cotton stalk shredder cum uprooter are main frame, converging unit power transmission unit, cutting and conveyor unit, shredding unit and uprooting unit. Descriptions of each component are

explained below. The specifications of developed cotton stalk shredder cum uprooter are presented in Table 1 and 2. The different views of developed cotton stalk shredder cum uprooter are shown in Fig. 1.

The cotton stalk shredder cum uprooter was fabricated at the department of FMPE, CAE, Raichur.

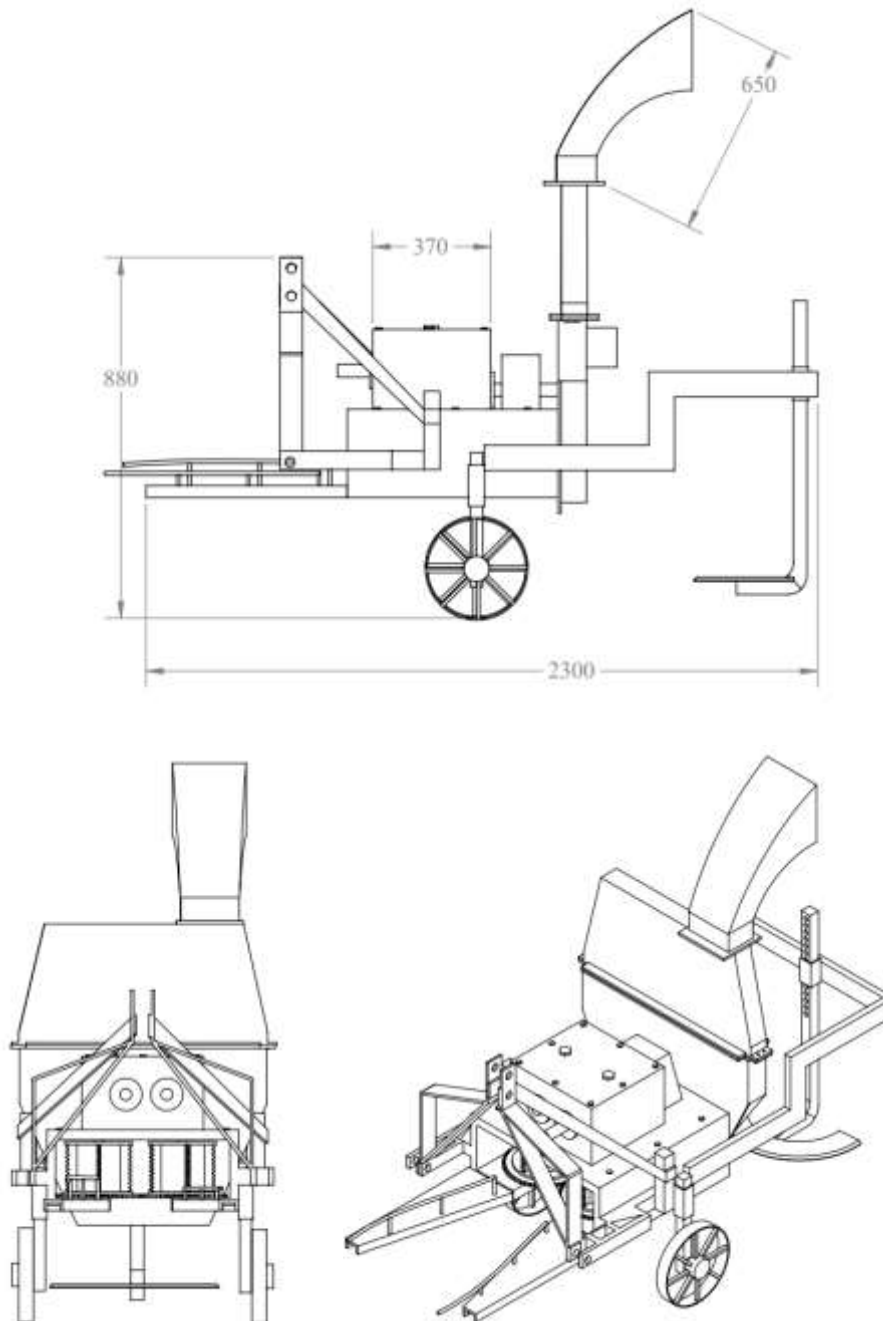

Fig. 1. Schematic diagrams and geometrical model of cotton stalk shredder cum uprooter (all dimension in mm)

2.3 Performance Evaluation of Developed Cotton Stalk Shredder Cum Uprooter in Field Condition

The assessment of performance was executed within the research domain situated in CAE, Raichur. The selected independent variables for examination were categorized into three levels based on the factorial CRBD experimental design, whereby a total of 27 trials were conducted. The sequence of trials was randomized. To determine the discrepancies between the responses and independent variables, the experiments were replicated thrice. The performance evaluation of the developed cotton stalk shredder cum uprooter is significantly influenced by the selection of variables, namely types of blades and rake angle. For the field evaluation of the tractor operated cotton stalk shredder cum uprooter, the

levels of variables chosen as independent variables were types of blades and rake angle, which are delineated as follows. The primary constituent of the shredder is the uprooter blade, which plays a crucial role in the process of uprooting residual stalks from the ground subsequent to shredding. The evaluation of the uprooter blade was undertaken by Solanki and Yadav [12], and entailed the assessment of three categories of blade: cross, sweep, and curved, which are showcased in Plates 1, 2, and 3. The rake angle can be precisely described as the angle formed between the direction of the cut and a line that is perpendicular to the cutting edge. In order to assess the efficacy of the cotton stalk shredder cum uprooter, Senthilkumar et al. [13] have chosen to examine three different rake angles, namely 10°, 20°, and 30°. These angles are meticulously presented in Plate 4.



Plate 1. Cross blade



Plate 2. Sweep blade



Plate 3. Curved blade



Plate 4. Tines

The evaluation of the cotton stalk shredder cum uprooter's various performance parameters, such as uprooting efficiency, draft requirement, power requirement, and fuel consumption, is deemed crucial. The aforementioned dependent variables were meticulously ascertained as described below. To determine the uprooting efficiency, a sample test was conducted. The sample area measured 1 × 1m, and the numbers of completely uprooted and partially uprooted plants (referred to as non-uprooters) were recorded and documented (Plate 5). The uprooting efficiency was then calculated as the ratio of the number of completely uprooted plants to the total number of plants in a row [12].

$$\text{Uprooting efficiency(\%)} = \frac{\text{Number of completely uprooted plants}}{\text{Total number of plants in a row}} \quad (1)$$

The measurement of draft was conducted in accordance with established methodologies. Specifically, the equipment was affixed to a tractor (A), which was subsequently towed by another tractor (B) via a dynamometer, as illustrated in Plate 6. Draft was assessed under two distinct conditions: firstly, when tractor A was in a neutral gear state while the equipment remained in an operational condition; and secondly, when the equipment was elevated. The discrepancy between these two measurements yielded the draft requirement of the equipment, as outlined by Mehta et al. [16]. The power requirement for the equipment was exclusively computed for the cotton stalk shredder cum uprooter, and was expressed in the form of an equation as per the study conducted by Mehta et al. in 2005 [16].



Plate 5. Uprooting efficiency



Plate 6. Measurement of draft of cotton stalk shredder cum uprooter using dynamometer



Plate 7. Measurement of fuel consumption of cotton stalk shredder cum uprooter

$$P = \frac{D \times S}{3.6} \quad \dots\dots(2)$$

Where,

P = Power, kW

D = Draft, kN

S = Speed of travel, km h⁻¹

The quantification of fuel consumption was achieved through the implementation of the standard refilling methodology. The fuel reservoir was replenished to its maximum capacity prior to and subsequent to the experiment. The quantity of refueling observed post-experimentation was meticulously gauged, thereby representing the authentic fuel consumption measurement for the test in question (Plate 7). This measurement was subsequently articulated in liters per hour.

2.4 Optimization of Machine and Operational Parameters of Cotton Stalk Shredder Cum Uprooter

Optimum process conditions are required to significantly enhance the performance of cotton stalk shredder cum uprooter. Numerical optimization has been conducted to evaluate the optimum types of blade and rake angle. In this study, different levels of each independent variable *viz.*, types of blade and rake angle were used for the design of experiments to study their effects on uprooting efficiency, draft requirement, power requirement and fuel consumption.

The performance evaluations were carried at three levels of types of blade (cross, sweep and

curved blade) and rake angle (10°, 20° and 30°). The dependent variables taken for cotton stalk shredder cum uprooter were on uprooting efficiency, draft requirement, power requirement and fuel consumption. Statistical analysis was carried out by using the Stat-Ease version 7 of Design-Expert software tool. A two factor randomized block design technique were used to analyse the effect of types of blade and rake angle on the performance of cotton stalk shredder cum uprooter.

3. RESULTS AND DISCUSSION

3.1 Effect of Types of Blade and Rake Angle on Uprooting Efficiency

The uprooting efficiency cotton stalk shredder cum uprooter varied from 88.23 per cent to 99.80 per cent at different types of blade and at different rake angle. The minimum uprooting efficiency of 88.23 per cent was found with sweep blade and at 10° rake angle whereas the maximum uprooting efficiency 99.80 per cent was found at curved blade and 10° rake angle. For curved blade the uprooting efficiency varied from 99.10 to 99.80 per cent at different rake angles. The minimum uprooting efficiency of 99.10 per cent was found at 10° whereas the maximum uprooting efficiency 99.80 per cent was found at 30° rake angle. For sweep blade the uprooting efficiency varied from 88.23 per cent to 94.12 per cent at different rake angles. The minimum uprooting efficiency of 88.23 per cent was found at 10° rake angle whereas the

maximum uprooting efficiency 94.12 per cent was found at 30 ° rake angle. For cross blade the uprooting efficiency varied from 93 per cent to 96 per cent at different rake angle. The minimum uprooting efficiency of 93 per cent was found at 10° rake angle whereas the maximum uprooting efficiency 96 per cent was found at 30 ° rake angle. From the Analysis of variance it was found that all the main effects such as types of blade (A) and rake angle (B), and their interaction effects (A × B) were significant at 1 and 5 per cent level indicating that all the factors have influence on uprooting efficiency of cotton stalk shredder cum uprooter. The mean value of uprooting efficiency found to be 94.98 per cent. The effects of different types of blade and rake angle on uprooting efficiency are presented in Fig. 2. From the figure it was observed that the uprooting efficiency changed with different types of blade and rake angle. However, the minimum uprooting efficiency of 88 per cent was found at sweep blade and 10° rake angle. The maximum uprooting efficiency of 99.80 per cent was found at curved blade for 10° rake angle. This is due to more contact area of the blade on the soil surface. The uprooting efficiency was increased with increased rake angle due to increase in depth of operation. The results are in agreement with the findings of Solanki and Yadav [12] Tapan et al. [17] and Gangade et al. [11].

3.2 Effect of Types of blade and Rake Angle on Draft Requirement

The draft requirement for the cotton stalk shredder cum uprooter varied from 1.78 to 4.98 kN, depending on the type of blade and the rake

angle. The minimum draft was recorded at 1.78 kN for the curved blade and 10° rake angle, while the maximum draft was observed for the curved blade and 30° rake angle, at 4.98 kN. The sweep blade had a minimum draft of 2.37 kN at 10° rake angle, and a maximum draft of 4.61 kN at 30° rake angle. Similarly, the cross blade had a minimum draft of 2.47 kN at 10° rake angle, and a maximum draft of 4.26 kN at 30° rake angle. Through the analysis of variance, it was determined that all the main effects, such as blade type (A) and rake angle (B), as well as their interaction effects (A × B), were significant at the 1 percent level. This suggests that all the factors have an impact on the draft requirement of the cotton stalk shredder cum uprooter. The mean draft value was determined to be 3.48 kN. The effects of blade type and rake angle on the draft requirement of the cotton stalk shredder cum uprooter are illustrated in Fig. 3. It was observed that the draft requirement increased with an increase in rake angle. The curved blade had a higher draft requirement at 30° rake angle than the sweep blade and cross blade. However, the minimum draft of 1.78 kN was recorded for the curved blade and 10° rake angle, while the maximum draft of 4.98 kN was recorded for the curved blade and 30° rake angle because of the increased contact area of the blade which led to increased draft. The draft requirement increased with an increase in rake angle due to the higher volume of soil handled, and an increase in soil resistance at higher depths. Therefore, the draft increased with an increase in blade type and rake angle. These findings are consistent with those of Solanki and Yadav [12] and Tapan et al. [17].

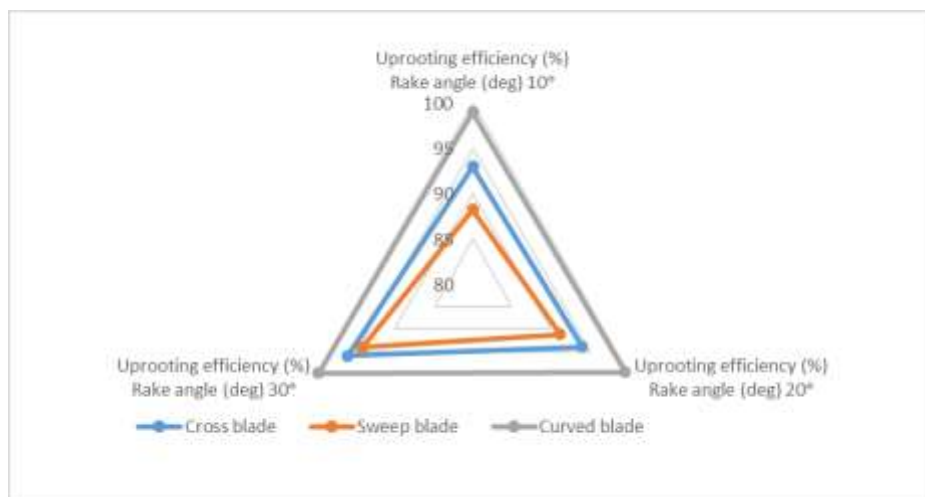

Fig. 2. Effect of types of blade on uprooting efficiency at different rake angle with 6 number of blades

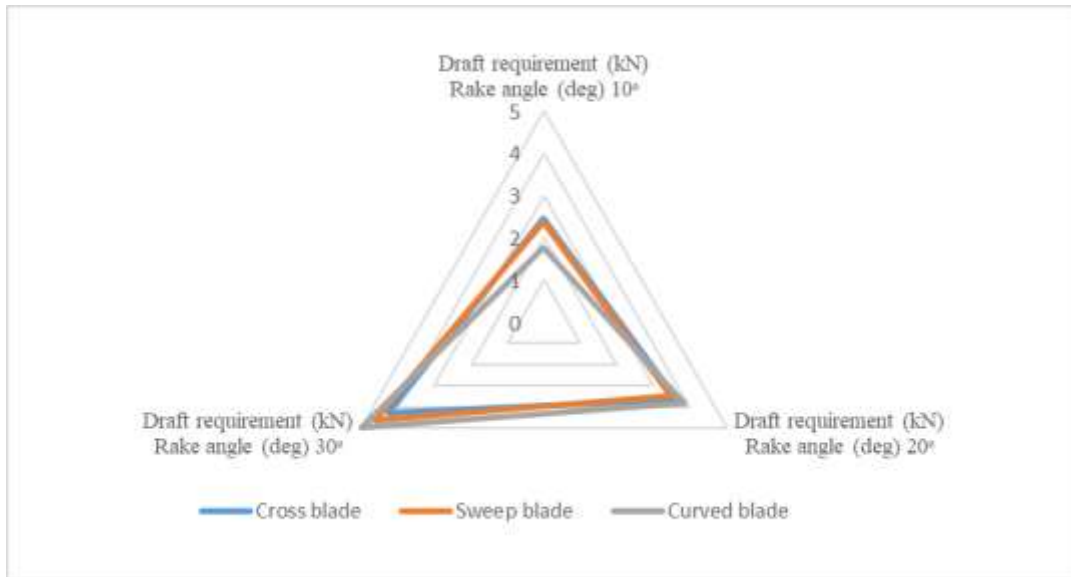

Fig. 3. Effect of types of blade on draft requirement at different rake angle with 6 number of blades

3.3 Effect of Types of Blade and Rake Angle on Power Requirement

The power requirement of the cotton stalk shredder cum uprooter was found to vary between 1.48 kW to 4.15 kW, depending on the type of blade and rake angle employed. Specifically, the minimum power requirement of 1.48 kW was observed for the curved blade and 10° rake angle, while the maximum power requirement of 4.15 kW was recorded for the curved blade and 30° rake angle. Similarly, the minimum power requirement of 1.97 kW was observed for the sweep blade and 10° rake angle, while the maximum power requirement of 3.84 kW was recorded for the sweep blade and 30° rake angle. Lastly, the minimum power requirement of 2.05 kW was observed for the cross blade and 10° rake angle, while the maximum power requirement of 3.55 kW was recorded for the cross blade and 30° rake angle. The analysis of variance revealed that all the main effects, including the types of blade (A), rake angle (B), and their interaction effects (A x B), were significant at the 1 and 5 per cent levels. This indicates that all the factors have an impact on the power requirement of the cotton stalk shredder cum uprooter. The mean value of power requirement was found to be 2.90 kW. The effects of different types of blade and rake angle on the power requirement of the cotton stalk shredder cum uprooter are presented in Fig. 4. The figure shows that the power requirement of the cotton stalk shredder cum

uprooter increased with an increase in rake angle. Furthermore, the power requirement was found to be more significant for the curved blade at 30° rake angle than for the sweep blade and cross blade. Notably, the minimum power requirement of 1.48 kW was recorded for the curved blade and 10° rake angle, while the maximum power requirement of 4.15 kW was recorded for the curved blade and 30° rake angle. This is attributed to the increased contact area of the blade with the soil, which in turn increases the draft and the power requirement. It was also observed that the power requirement of the cotton stalk shredder cum uprooter increased with an increase in rake angle due to the higher volume of soil handled and the increase in soil resistance at greater depths. These findings are consistent with previous studies conducted by Solanki and Yadav [12] and Tapan et al. [17].

3.4 Effect of Types of Blade and Rake Angle on Fuel Consumption

The fuel consumption of the cotton stalk shredder cum uprooter exhibited variations ranging from 2.38 l/h to 4.02 l/h, contingent upon different types of blades and rake angles. The curved blade with a rake angle of 10° registered the lowest fuel consumption at 2.38 l/h, while the curved blade with a rake angle of 30° registered the highest fuel consumption at 4.02 l/h. The fuel consumption for the sweep blade ranged from 2.46 l/h to 3.89 l/h at different rake angles, with

2.46 l/h being the lowest fuel consumption at a rake angle of 10° and 3.89 l/h being the highest fuel consumption at a rake angle of 30°. The fuel consumption for the cross blade ranged from 2.68 l/h to 3.42 l/h at different rake angles, with 2.68 l/h being the lowest fuel consumption at a rake angle of 10° and 3.42 l/h being the highest fuel consumption at a rake angle of 30°. The analysis of variance indicated that all the primary effects, such as types of blade (A) and rake angle (B), and their interaction effects (A × B), were significant at a 1% level, signifying that all the factors had an impact on the fuel consumption of the cotton stalk shredder cum uprooter. The mean value of fuel consumption was found to be 3.10 l/h. The effects of different

types of blades and rake angles on fuel consumption are depicted in Fig. 5. The figures revealed that the fuel consumption increased with an increase in the types of blades and rake angles. However, the minimum fuel consumption of 2.38 l/h was recorded for the curved blade and 10° rake angle. The maximum fuel consumption of 4.02 l/h was recorded for the curved blade and 30° rake angle, as the increased contact area of the blade enhanced the draft and power, thereby increasing the fuel consumption. The fuel consumption increased with an increase in rake angle due to a larger volume of soil handled per unit time. These findings align with the research conducted by Solanki and Yadav [12] and Tapan et al. [17].

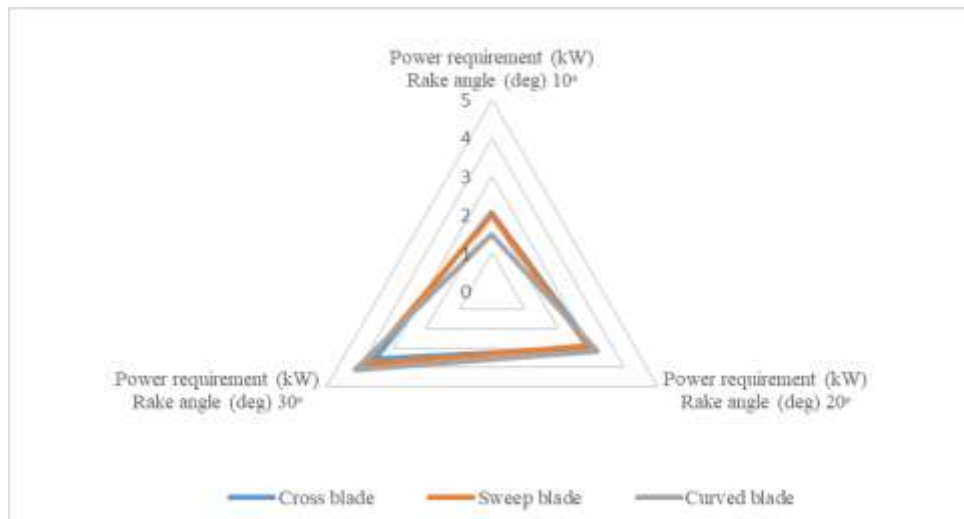

Fig. 4. Effect of types of blade on power requirement at different rake angle with 6 number of blades

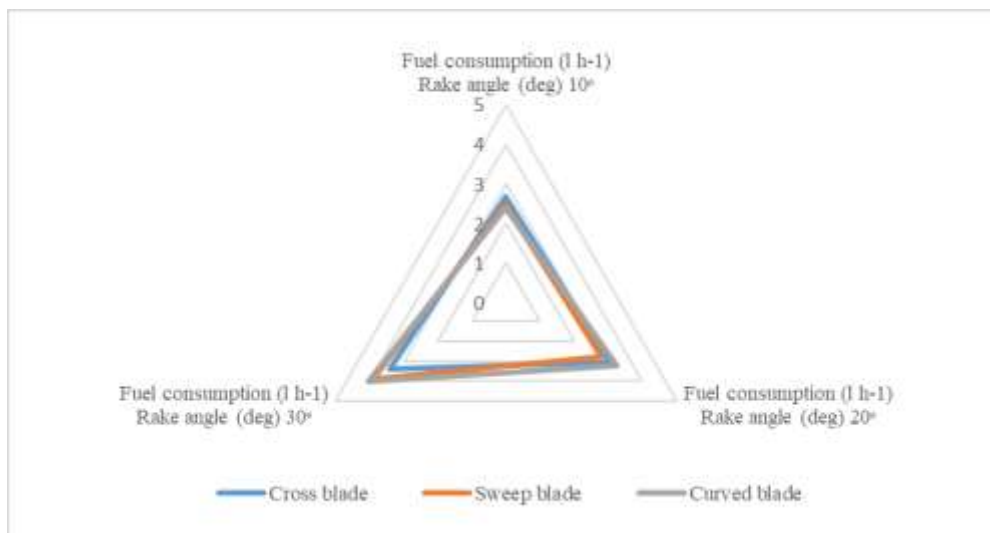

Fig. 5. Effect of types of blade on fuel consumption at different rake angle with 6 number of blades

3.5 Optimization of Machine and Operational Parameters for Cotton Stalk Shredder Cum Uprooter

The experiments were conducted in order to assess the performance of a newly developed cotton stalk shredder cum uprooter under field conditions, with the aim of optimizing both the machine and operational parameters, such as the types of blade and rake angle. The parameters selected for the optimization process included uprooting efficiency, draft requirement, power requirement, and fuel consumption, with the ultimate goal of maximizing uprooting efficiency while minimizing draft requirement, power requirement, and fuel consumption. A numerical optimization technique was employed

to optimize the operational parameters based on response constraints. The constraints utilized for the optimization process are presented in Table 3. The optimization process was carried out using Design Expert software with the CRBD method. The numerical optimization was executed, and the resultant outcomes are presented in Table 4. The desirability of the cotton stalk shredder cum uprooter for the optimized values of dependent and independent variables was found to be 0.980. This desirability was observed with a curved blade, 10° rake angle, and a draft requirement of 1.78 kN, a power requirement of 1.48 kW, fuel consumption of 2.38 l h⁻¹, and an uprooting efficiency of 99.80%. The desirability graph is depicted in Fig. 6.

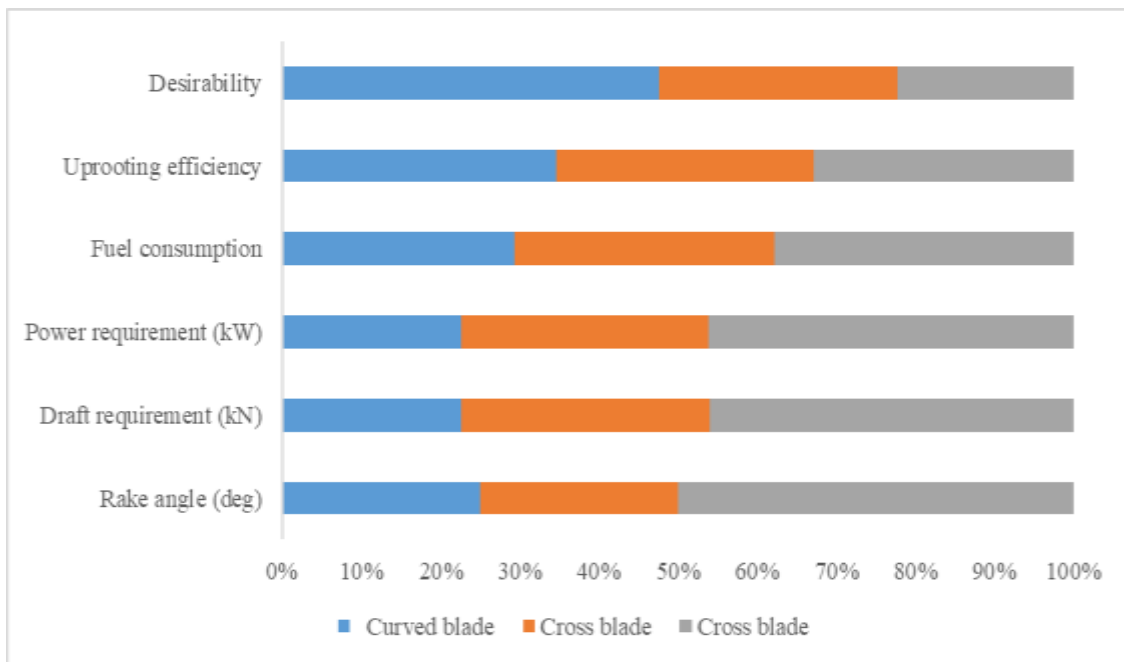

Fig. 6. Desirability graph of cotton stalk shredder cum uprooter

Table 3. Optimized values for cotton stalk shredder cum uprooter based on types of blade and rake angle

Types of blade	Rake angle (deg)	Draft requirement (kN)	Power requirement (kW)	Fuel consumption (l h ⁻¹)	Uprooting efficiency (%)	Desirability
Curved blade	10	1.78	1.48	2.38	99	0.98
Cross blade	10	2.47	2.05	2.68	93	0.62
Cross blade	20	3.62	3.03	3.07	94	0.46

Table 4. Multi response numerical optimization constraints for field evaluation of cotton stalk shredder cum uprooter

Parameter	Goal	Lower	Upper	Importance
Types of blade	In range	Curved blade	Curved blade	3
Rake angle, deg	In range	10°	30°	3
Uprooting efficiency, %	Maximize	88.00	99.80	3
Draft requirement, kN	Minimize	1.78	4.98	3
Power requirement, kW	Minimize	1.48	4.15	3
Fuel consumption, l h ⁻¹	Minimize	2.38	4.02	3

4. CONCLUSION

A significant amount of cotton stalk is generated annually in India. Due to a scarcity of labor and high investment costs, these stalks are often burned in the fields as crop residues. The uprooting efficiency was observed to be at its maximum, reaching 99.80%, when utilizing a curved blade with a rake angle of 10°, six blades, and a peripheral speed of 34.88 m/s. In the case of the cotton stalk shredder cum uprooter, the minimum draft requirement was found to be 1.78 kN for the curved blade with a rake angle of 10°, six blades, and a peripheral speed of 34.88 m/s. Similarly, the minimum power requirement observed for the cotton stalk shredder cum uprooter was 1.48 kW under the same conditions. Lastly, the minimum fuel consumption of the cotton stalk shredder cum uprooter was found to be 2.38 l/h, again using the curved blade with a rake angle of 10°, six blades, and a peripheral speed of 34.88 m/s.

COMPETING INTERESTS

Authors have declared that no competing interests exist.

REFERENCES

- Anonymous. State-wise/year-wise area, production and yield in India. Cotton Advisory Board. 2018;108.
- Senthilkumar T, Thilagam VK. Study on effect of incorporation of shredded cotton stalks by cotton stalk shredder on soil properties; 2015.
- Rathinakumari AC, Jesudas DM. Design and development of tractor operated onion set planter. Indian Journal of Agricultural Sciences. 2015;85(8):1038-1041.
- Hiloidhari M, Das D, Baruah DC. Bioenergy potential from crop residue biomass in India. Renewable and sustainable energy reviews. 2014;32:504-512.
- Tribelhorn RE, Smith JL. Chopping energy of forage harvester. Transaction of American Society of Agricultural Engineers. 1974;5(1):423-427.
- Rider, Barr. Crop production equipment, Forage harvesters and blowers. John Deere Publishers, American. 1976;130-132.
- Persson S. Mechanics of cutting plant material. The American Society of Agricultural Engineers/ Michigan, UAS. 1987;59.
- Visvanathan R, Sreenarayanan VV, Swaminathan KR. Effect of knife angle and velocity on energy required to cut cassava tubers. Journal of Agricultural Engineering research. 1996;64 (1):99-102.
- Pasikatan MC, Salazae GC, Quick GR. A low - cost straw and forage chopper. Agricultural Mechanization in Asia, Africa and Latin America. 1997;28(1):43-46.
- Chattopadhyay PS, Pandey KP. Effect of knife and operational parameters on energy requirement in flail forage harvesting. Journal of Agricultural Engineering Research. 1999;73(1):3-12.
- Gangade CN, Patil PG, Dhanphule SS. Comparative study of different methods of cotton stalk removing. PKV Research Journal. 2000;24(2):87-89.
- Solanki HB, Yadav R. Development and performance evaluation of tractor operated plant uprooter for castor crop. Ama, Agricultural Mechanization in Asia, Africa & Latin America. 2009;11(2):41.
- Senthilkumar T, Manian R, Kathirvel K. Effect of blade and operational parameters on shredding efficiency of an experimental cotton stalk shredder. AMA-Agricultural Mechanization in Asia Africa and Latin America. 2011;42(3):9.
- Suliman AERE, Nasr GEDM, Baiomy MA, Eid AR. Study of some engineering factors concerning the performance of the affecting tool in crop residues shredder.

- Misr Journal of Agricultural Engineering. 2010;27(4):1555-1571.
15. Alaa AA, El-Atty A, Hassan MA, Afify MK, El-Shal HM. Performance evaluation of a local machine for cutting and chopping cotton stalks. Zagazig Journal of Agricultural Research. 2016;43(5):1735-1750.
16. Mehta ML, Verma SR, Misra SK, Sharma VK. Testing and evaluation of Agricultural Machinery. Daya Publishing House, Delhi; 2005.
17. Tapan KK, Indra M, Srivastava AP. Design and development of tractor operated onion harvester. Indian Journal of Agricultural Sciences. 2009;81(6):528-532.

© 2023 Srinidhi et al.; This is an Open Access article distributed under the terms of the Creative Commons Attribution License (<http://creativecommons.org/licenses/by/4.0>), which permits unrestricted use, distribution, and reproduction in any medium, provided the original work is properly cited.

Peer-review history:

The peer review history for this paper can be accessed here:
<https://www.sdiarticle5.com/review-history/108668>