



Generalizing the Asymmetric Run-length-limited Systems

D. Ahmadi Dastjerdi*¹ and S. Jangjooye Shaldehi¹

¹Faculty of Mathematics, University of Guilan, Iran

**Original Research
Article**

Received: 11 October 2013
Accepted: 13 January 2014
Published: 19 February 2014

Abstract

For $i = 1, 2$, if X_i is a synchronized system generated by $V_i = \{v^i \alpha_i : \alpha_i v^i \alpha_i \in \mathcal{B}(X_i), \alpha_i \notin v^i\}$ where α_i is a synchronizing word for X_i , then a natural generalization of an asymmetric-RLL(d_1, k_1, d_0, k_0) systems is a coded system Z generated by $\{v^1 \alpha_1 v^2 \alpha_2 : v^i \alpha_i \in V_i, i = 1, 2\}$. We investigate the dynamical properties of Z . We show that Z is sofic or has specification with variable gap length (SVGL) if and only if X_1 and X_2 are so. Also, if Z is SFT or AFT, then X and Y are SFT or AFT respectively and sufficient conditions for the converse will be given.

Keywords: shift of finite type; sofic; almost-finite-type; synchronized; coded system.

2010 Mathematics Subject Classification: 37B10

1 Introduction

Recall that the Run-length-limited (RLL) (cf. (1)) and the Maximum Transition Run (MTR) constrained systems (cf. (2)) are used to improve timing and detection performance in storage channels. In particular, the MTR code, introduced by Moon and Brickner (cf. (2)), are to provide coding gain for extended partial response channels. The RLL code denoted by $X(d, k)$ limits the run of 0 to be at least d and at most k whereas the $MTR(j, k)$ code limits the run of 0 to be at most k and the run of 1 at most j . When there is no restriction on the runs of 0, we say that $k = \infty$ and it is common then to denote such a constraint by $MTR(j)$. For generalizing MTR codes, consider the asymmetric-RLL(d_1, k_1, d_0, k_0) constraint which is the set of binary sequences whose runs of 1's have length between d_1 and k_1 and the runs of 0's between d_0 and k_0 . In the case that $d_1 = d_0 = 1, k_1 = j$ and $k_0 = k$, this constraint coincides with $MTR(j, k)$.

One may define an asymmetric-RLL(d_1, k_1, d_0, k_0) as follows. Let $S = \{d_0 - 1, d_0, \dots, k_0 - 1\} \subseteq \mathbb{N}_0$ and let $X = X(d_0 - 1, k_0 - 1)$ be the RLL system associated to S . Then X is the space generated by $V = \{0^s 1 : s \in S\}$, that is, the space constructed by concatenating the words in V . Now consider $S' = \{d_1 - 1, d_1, \dots, k_1 - 1\} \subseteq \mathbb{N}_0$ and the space $Y = X(d_1 - 1, k_1 - 1)$ generated by $W = \{1^{s'} 0 : s' \in S'\}$. The word $\alpha = 1$ (resp. $\beta = 0$) is a synchronizing word in X (resp. Y) and our asymmetric-RLL(d_1, k_1, d_0, k_0) is the space generated by $\{vw : v \in V, w \in W\}$. On the

*Corresponding author: E-mail: dahmadi1387@gmail.com

other hand, any synchronized system X with a synchronizing word α is generated by $\{v\alpha : \alpha v\alpha$ is a word in X and $\alpha \not\subseteq v\}$. If Y is another synchronized system with a synchronized word β and a set of generators $W_\beta = \{w\beta : \beta w\beta \text{ a word in } Y \text{ and } \beta \not\subseteq w\}$, then a natural generalization for an asymmetric-RLL(d_1, k_1, d_0, k_0) constraint is a coded system Z denoted by $X\&Y$ and generated by $\{v\alpha w\beta : v\alpha \in V_\alpha, w\beta \in W_\beta\}$. Dynamical properties of this generalized system depend on α and β ; however, here, we are interested in those dynamical properties which are independent of the synchronized words.

In Theorem 3.3 (resp. Theorem 3.5), it is shown that X and Y are sofic (resp. SVGL) if and only if $Z = X\&Y$ is sofic (resp. SVGL). Also, if $Z = X\&Y$ is SFT, near Markov or AFT, then both X and Y are SFT, near Markov or AFT respectively (Theorem 3.6). But the converse does not hold necessarily. Then we give sufficient conditions such that the converse of Theorem 3.6 holds (Theorem 3.10).

2 Background and Notations

In this section, we will bring the basic definitions in symbolic dynamics on finite alphabet \mathcal{A} . For justification of our claims see (1).

Equip \mathcal{A} with discrete topology and $\mathcal{A}^{\mathbb{Z}}$ with product topology. Then $\mathcal{A}^{\mathbb{Z}}$ is a Cantor set and $\sigma : \mathcal{A}^{\mathbb{Z}} \rightarrow \mathcal{A}^{\mathbb{Z}}$ defined by $(\sigma(x))_i = x_{i+1}$ is called the *shift map*. A *block* (or *word*) over \mathcal{A} is a finite sequence of symbols from \mathcal{A} . It is convenient to include ε , the sequence of no symbols which is called the *empty word*. If x is a point in $\mathcal{A}^{\mathbb{Z}}$ and $i \leq j$, then we will denote a word of length $j - i$ by $x_{[i, j]} = x_i x_{i+1} \dots x_j$. If $n \geq 1$, then u^n denotes the concatenation of n copies of u , and put $u^0 = \varepsilon$. Let $w = w_0 w_1 \dots w_{p-1}$ be a word of length p . The least period of w is the smallest integer q such that $w = (w_0 w_1 \dots w_{q-1})^m$ where $m = \frac{p}{q}$ must be an integer. The word w is primitive if its least period equals its length p .

Let \mathcal{F} be a collection of some words over \mathcal{A} . Let $X_{\mathcal{F}}$ be a non-empty closed subset of $\mathcal{A}^{\mathbb{Z}}$ and so that $X_{\mathcal{F}}$ does not contain any word in \mathcal{F} . This set \mathcal{F} is called the set of *forbidden blocks* over \mathcal{A} . Then any subshift $X \subseteq \mathcal{A}^{\mathbb{Z}}$ is a $X_{\mathcal{F}}$ for some collection of forbidden blocks. If \mathcal{F} is finite, then $X_{\mathcal{F}}$ is called *shift of finite type* (SFT).

Let $\mathcal{B}_n(X)$ denote the set of all admissible n words. The *language* of X is the collection $\mathcal{B}(X) = \bigcup_{n=0}^{\infty} \mathcal{B}_n(X)$. A shift space X is *irreducible* if for every ordered pair of words $u, v \in \mathcal{B}(X)$ there is a word $w \in \mathcal{B}(X)$ so that $uwv \in \mathcal{B}(X)$. We say $v \in \mathcal{B}(X)$ is *synchronizing* if whenever uv and vv are in $\mathcal{B}(X)$, then $uvw \in \mathcal{B}(X)$. An irreducible shift space X is a *synchronized system* if it has a synchronizing word (3).

Fix integers m and n with $m \leq n$ and let \mathcal{A} and \mathcal{D} be alphabets and X a shift space over \mathcal{A} . Define the $(m + n + 1)$ -*block map* $\Phi : \mathcal{B}_{m+n+1}(X) \rightarrow \mathcal{D}$ by

$$y_i = \Phi(x_{i-m} x_{i-m+1} \dots x_{i+n}) = \Phi(x_{[i-m, i+n]}) \tag{2.1}$$

where $y_i \in \mathcal{D}$. This Φ induces a map $\Phi_\infty = \Phi_\infty^{[-m, n]} : X \rightarrow \mathcal{D}^{\mathbb{Z}}$ called the *sliding block code* with *memory* m and *anticipation* n defined by $y = \Phi_\infty(x)$ with y_i given by (1.1). An onto sliding block code $\Phi_\infty : X \rightarrow Y$ is called a *factor code*. In this case, we say that Y is a factor of X . The map Φ_∞ is a *conjugacy*, if it is invertible.

An *edge shift*, denoted by X_G , is a shift space consisting of all bi-infinite walks in a directed graph G . Any path $\pi \in G$ initiates at a vertex denoted by $i(\pi)$ and terminates at a vertex $t(\pi)$.

A *labeled graph* \mathcal{G} is a pair (G, \mathcal{L}) where G is a graph with edge set \mathcal{E} and the labeling $\mathcal{L} : \mathcal{E} \rightarrow \mathcal{A}$. Then a subshift $X_{\mathcal{G}}$ is induced by \mathcal{L}_∞ which it is the set of sequences obtained by reading the labels of walks on G ,

$$X_{\mathcal{G}} = \overline{\{\mathcal{L}_\infty(\xi) : \xi \in X_G\}} = \overline{\mathcal{L}_\infty(X_G)}. \tag{2.2}$$

We say \mathcal{G} is a *presentation* or a *cover* of $X_{\mathcal{G}}$. If G is finite, then $X_{\mathcal{G}}$ is called *sofic* and $X_{\mathcal{G}} = \mathcal{L}_\infty(X_G)$.

Let $\mathcal{G} = (G, \mathcal{L})$ be a labeled graph. A word $v \in \mathcal{B}(X_{\mathcal{G}})$ is a *magic word* for \mathcal{G} if all paths in G labeled v terminate at the same vertex.

A labeled graph $\mathcal{G} = (G, \mathcal{L})$ is *right-resolving* if for each vertex I of G the edges starting at I carry different labels. Let $I \in \mathcal{V}$ be a vertex of \mathcal{G} . The *follower set* $F(I)$ of I in \mathcal{G} is the collection of labels of paths starting at I . The labeled graph \mathcal{G} is *follower-separated* if distinct vertices have distinct follower sets.

A *minimal right-resolving presentation* of a sofic shift X is a right-resolving presentation of X having the fewest vertices among all right-resolving presentations of X . A minimal right-resolving presentations of an irreducible sofic shift is unique up to conjugacy and called the *Fischer cover* of X . A right-resolving graph \mathcal{G} is the Fischer cover of X if and only if it is irreducible and follower-separated.

Let X be a shift space and $w \in \mathcal{B}(X)$. The *follower set* $F(w) = F_X(w)$ of w is defined by $F(w) = \{v \in \mathcal{B}(X) : wv \in \mathcal{B}(X)\}$. A shift space X is sofic if and only if it has a finite number of follower sets (1, Theorem 3.2.10).

A labeled graph is *right-closing* with delay D if whenever two paths of length $D + 1$ start at the same vertex and have the same label, then they must have the same initial edge. Similarly, left-closing will be defined. A labeled graph is *bi-closing*, if it is simultaneously right-closing and left-closing.

An irreducible sofic shift is called *almost-finite-type* (AFT) if it has a bi-closing presentation (1). Nasu in (4) showed that an irreducible sofic shift is AFT if and only if its Fischer cover is left-closing.

Now we review the concept of the Fischer cover for a not necessarily sofic system (cf. (5)). Let $x \in \mathcal{B}(X)$. Then $x_+ = (x_i)_{i \in \mathbb{Z}^+}$ (resp. $x_- = (x_i)_{i < 0}$) is called *right (resp. left) infinite X-ray*. For a left infinite X -ray, say x_- , its follower set is $\omega_+(x_-) = \{x_+ \in X^+ : x_-x_+ \text{ is a point in } X\}$. Consider the collection of all follower sets $\omega_+(x_-)$ as the set of vertices of a graph X^+ . There is an edge from I_1 to I_2 labeled a if and only if there is an X -ray x_- such that x_-a is an X -ray and $I_1 = \omega_+(x_-)$, $I_2 = \omega_+(x_-a)$. This labeled graph is called the *Krieger graph* for X . If X is a synchronized system with synchronizing word α , the irreducible component of the Krieger graph containing the vertex $\omega_+(\alpha)$ is called the *right Fischer cover* of X . We are working only with coded synchronized systems which are irreducible. In this situation, alike irreducible sofics, the right Fischer cover is just called the Fischer cover.

The *entropy* of a shift space X is defined by $h(X) = \lim_{n \rightarrow \infty} (1/n) \log |\mathcal{B}_n(X)|$.

3 Intertwined Synchronized Systems

A shift space that can be presented by an irreducible countable labeled graph is called a *coded system*. Equivalently, a coded system X is the closure of the set of sequences obtained by freely concatenating the words in a list of words, called the set of generators, over a finite alphabet (1). A coded system is irreducible and has a dense set of periodic points (5). Coded systems were introduced by Blanchard and Hansel in (3) who also showed that the class of the coded systems is the smallest class of subshifts which contains the synchronized systems and is closed under factors (3, Proposition 4.1). A brief introduction to coded systems can be found in (1, Section 13.5).

Our objective is to study the synchronized systems. Recall that in a synchronized system X , for any synchronizing word $\alpha = \alpha_1 \cdots \alpha_p$, X is generated by

$$V = V_\alpha = \{v\alpha \in \mathcal{B}(X) : \alpha v\alpha \in \mathcal{B}(X), \alpha \not\subseteq v\}. \tag{3.1}$$

Now we state our main definition.

Definition 3.1. For $1 \leq i \leq \ell$, let $X_i = X_{V_i}$ be a coded system with a synchronizing word α_i and generated by

$$V_i = V_{\alpha_i} = \{v^{(i)}\alpha_i : \alpha_i v^{(i)}\alpha_i \in \mathcal{B}(X_i), \alpha_i \not\subseteq v^{(i)}\}.$$

The coded system $Z = Z(V_1, \dots, V_\ell)$ generated by

$$\{v^{(1)}\alpha_1 v^{(2)}\alpha_2 \cdots v^{(\ell)}\alpha_\ell : v^{(i)}\alpha_i \in V_{(i)}\}$$

is called the *intertwined system* of X_1, \dots, X_ℓ and is denoted by

$$Z = X_1 \& X_2 \& \dots \& X_\ell.$$

Since the problems arising from intertwining of some finitely many systems are basically the same as intertwining of two systems, we will concentrate on intertwining of two systems $X = X_V$ and $Y = Y_W$ generated by

$$V = V_\alpha = \{v\alpha : \alpha v \in \mathcal{B}(X), \alpha \not\subseteq v\} \quad \text{and} \quad W = W_\beta = \{w\beta : \beta w \in \mathcal{B}(Y), \beta \not\subseteq w\} \quad (3.2)$$

respectively. Note that for $w\beta \in W_\beta$, $\alpha w\beta$ is a synchronizing word for Z . So our first observation is

Lemma 3.1. *Suppose X and Y are synchronized and V and W as in (3.2). Then Z , the intertwined of X and Y , is synchronized.*

One of the best tools to study the dynamics of a synchronized system is through one of its covers, in particular, its Fischer cover. So we construct a cover for $Z = X \& Y$ from \mathcal{G}_X and \mathcal{G}_Y the Fischer covers of X and Y respectively.

Let $\alpha = \alpha_1 \alpha_2 \dots \alpha_p$ (resp. $\beta = \beta_1 \beta_2 \dots \beta_q$) be the synchronizing word for X (resp. Y) and π_u any path labeled u . Then there is a unique vertex $I_\alpha \in \mathcal{V}(\mathcal{G}_X)$ (resp. $I_\beta \in \mathcal{V}(\mathcal{G}_Y)$) such that $t(\pi_{u\alpha}) = I_\alpha$ (resp. $t(\pi_{u\beta}) = I_\beta$) for $u \in \mathcal{B}(X)$ (resp. $u \in \mathcal{B}(Y)$). If all vertices $t(\pi_{v\alpha_1 \dots \alpha_i})$, $1 \leq i \leq p$ and $t(\pi_{w\beta_1 \dots \beta_j})$, $1 \leq j \leq q$ have just one inner edge, then to construct a cover \mathcal{G}_Z for Z , cut off all inner edges of I_α (resp. I_β) which are the last edge of some π_α (resp. π_β) from I_α (resp. I_β) and paste them to I_β (resp. I_α) as its inner edges. By this construction, for any word $v\alpha w\beta$, we will have a path $\pi_{v\alpha w\beta}$ and in fact any other path in this cover is labeled by a subword of some $v_1 \alpha w_1 \beta \dots v_k \alpha w_k \beta$, $v_i \alpha \in V$, $w_i \beta \in W$.

The above cut and paste process at I_α and I_β may not give a cover for Z when one of the vertices along a path labeled by the synchronizing word α in G_X or β in G_Y has more than one inner edges. Suppose for instance there are two inner edges e_{α_i} and e_a , $\alpha_i \neq a \in \mathcal{A}$ at $t(\pi_{\alpha_1 \dots \alpha_i})$ along the path π_α . Then the above cut and paste process at I_α and I_β gives a cover with a path labeled $\zeta = a\alpha_{i+1} \dots \alpha_p w\beta$. But it could well happen that $\zeta \notin \mathcal{B}(Z)$. To overcome this problem, by using the in-splitting technique (1, Section 2.4), we replace \mathcal{G}_X (resp. \mathcal{G}_Y) by a cover \mathcal{G}_X^α (resp. \mathcal{G}_Y^β) so that the inner edges of $t(\pi_{\alpha_1 \dots \alpha_i})$ (resp. $t(\pi_{\beta_1 \dots \beta_j})$) are all labeled α_i (resp. β_j).

Now we give a detailed explanation of how our in-splitting takes place. Set $G_X = G$ and denote by I_α the unique vertex in $\mathcal{V}(G)$ where any path labeled α terminates. Any other vertex is denoted by $I_{\alpha u}$ by applying the following convention. If there are several paths $\pi_{\alpha u_i}$ all terminating at $I_{\alpha u}$, then u is amongst the ones with shortest length and then the least lexicographic order.

Fix $I = I_{\alpha u_1} \in \mathcal{V}(G)$ and assume that \mathcal{E}_I , the set of inner edges of I , has more than one element. Note that this means that there are at least two paths $\pi_{\alpha u_1}$ and $\pi_{\alpha u_2}$ such that $I = t(\pi_{\alpha u_1}) = t(\pi_{\alpha u_2})$. Suppose $u_i = c_{i_1} \dots c_{i_{k_i}} \alpha_1 \dots \alpha_{l_i} \in \mathcal{B}(X)$, $i = 1$ or 2 . If one of the following holds, then we do not do the splitting.

1. both $\alpha_1 \dots \alpha_{l_1}$ and $\alpha_1 \dots \alpha_{l_2}$ are empty words;
2. $\alpha_1 \dots \alpha_{l_1}$ (resp. $\alpha_1 \dots \alpha_{l_2}$) is not empty word and $c_{i_1} \dots c_{i_{k_1}} \alpha_1 \dots \alpha_{l_1} \dots \alpha_p = c_{i_1} \dots c_{i_{k_1}} \alpha$ (resp. $c_{i_1} \dots c_{i_{k_2}} \alpha$) is not admissible;
3. cases (1) and (2) do not hold and $l_1 = l_2$.

(1) and (2) say that if J is not a vertex on a path π_α , then in-splitting will not be done.

Now we set up to see which vertices on π_α requires in-splitting and how this happens. Note that case (3) above excludes some cases. Set $\mathcal{G}_1 = \mathcal{G}$ and let

$$\mathcal{V}_{\mathcal{G}_1}(\alpha_1) = \{I \in \mathcal{V}(\mathcal{G}_1) : I = t(e_{\alpha_1}), e_{\alpha_1} \text{ is the first edge labeled } \alpha_1 \text{ on a path labeled } \alpha\}. \quad (3.3)$$

For $I \in \mathcal{V}_{\mathcal{G}_1}(\alpha_1)$, partition \mathcal{E}_I to $P_I^1(\alpha_1) = \{e_1 : \mathcal{L}(e_1) = \alpha_1\}$ and $P_I^2(\alpha_1)$ for the remaining edges. Do an in-split for I with respect to this partition and call the new cover $\mathcal{G}_2 = (G_2, \mathcal{L}_2)$.

Let $\mathcal{V}_{G_2}(\alpha_1\alpha_2) = \{I \in \mathcal{V}(G_2) : I = t(e_{\alpha_1}e_{\alpha_2}), e_{\alpha_1}e_{\alpha_2} \text{ be the first 2 edges with label } \alpha_1\alpha_2 \text{ of a path labeled } \alpha\}$. Partition $\mathcal{E}_I, I \in \mathcal{V}_{G_2}(\alpha_1\alpha_2)$ to $P_I^1(\alpha_1\alpha_2) = \{e_2 : t(e_1e_2) = I \text{ for some } e_1, \mathcal{L}_2(e_1e_2) = \alpha_1\alpha_2\}$ and $P_I^2(\alpha_1\alpha_2) = \mathcal{E}_I \setminus P_I^1(\alpha_1\alpha_2)$. By the same procedure, $\mathcal{G}_{k+1}, P_I^1(\alpha_1\alpha_2 \cdots \alpha_k)$, and $P_I^2(\alpha_1\alpha_2 \cdots \alpha_k), 1 \leq k \leq p$ will be constructed. Set $\mathcal{G}^\alpha = \mathcal{G}_p = (G_p, \mathcal{L}_p)$.

Suppose in-splitting occurs at $I \in \mathcal{V}(G_k)$ and let \mathcal{E}^I be the set of outer edges of I . Then corresponding to I , there are two vertices I_1 and I_2 in $\mathcal{V}(G_{k+1})$ with $\mathcal{E}^I = \mathcal{E}^{I_1} = \mathcal{E}^{I_2}$. For $e \in \mathcal{E}$, let $e(i)$ be the corresponding edge in \mathcal{E}^{I_i} with the same label as e . We collect some properties of \mathcal{G}^α in the following theorem.

Theorem 3.2. *Let X be a synchronized system with a synchronized word $\alpha = \alpha_1 \cdots \alpha_p$, a generator V as (3.1) and the Fischer cover $\mathcal{G} = (G, \mathcal{L})$. Then*

1. \mathcal{G}^α and \mathcal{G} are conjugate.
2. Let $e_{\alpha_1} \cdots e_{\alpha_k}, 1 \leq k < p$ be a subpath of a path labeled $\alpha, \mathcal{L}_p(e_{\alpha_1} \cdots e_{\alpha_k}) = \alpha_1 \cdots \alpha_k$ and let $I = t(e_{\alpha_1} \cdots e_{\alpha_k})$. Then all the inner edges of I have the same label α_k .
3. Let $u = u_1 \cdots u_k \in \mathcal{B}(X)$ and suppose $\pi = e_{u_1} \cdots e_{u_k} e_{\alpha_i} \cdots e_{\alpha_p}$ is a path so that $\mathcal{L}_p(\pi) = u_1 \cdots u_k \alpha_i \cdots \alpha_p$ and $e_{\alpha_i} \cdots e_{\alpha_p}$ is a subpath of a path labeled α , then either $u\alpha_i \cdots \alpha_p \subseteq \alpha$ or $u\alpha_i \cdots \alpha_p = v\alpha_1 \cdots \alpha_p$ for some $v \in \mathcal{B}(X)$.
4. If X is sofic, then \mathcal{G}^α is a finite labeled graph. Also, if \mathcal{G} is left-closing with delay D , then \mathcal{G}^α will be left-closing with delay $D + p - 1$.

So corresponding to (X, α) (resp. (Y, β)) a cover \mathcal{G}_X^α (resp. \mathcal{G}_Y^β) arises whose any vertex along a path π_α (resp. π_β) has just one unique inner edge. Applying the above cut and paste process at $I_\alpha \in \mathcal{V}(\mathcal{G}_X^\alpha)$ and $I_\beta \in \mathcal{V}(\mathcal{G}_Y^\beta)$ gives rise to a cover \mathcal{G}_Z called the *intertwined cover* for $Z = X \& Y$.

Definition 3.2. Let G_{Z_X} be the subgraph of G_Z corresponding to G_X , that is, consisting of all the paths in G_Z labeled $v\alpha, v \in V$ and starting from I_α and terminating at I_β .

Remark 3.1. (1). Note that \mathcal{G}_{Z_X} is not irreducible and \mathcal{G}_{Z_X} and \mathcal{G}_{Z_Y} have only vertices I_α and I_β in common. However, unlike $\mathcal{G}_X^\alpha, \mathcal{G}_{Z_X}$ is follower separated. In fact, the only vertices in \mathcal{G}_X^α which have the same follower sets are those vertices in the path labeled α . So if an in-splitting is required at $t(e_{\alpha_i})$, then instead of $t(e_{\alpha_i})$, two vertices emerges; one is not preceded by $\alpha_1 \cdots \alpha_i$ and for this vertex, a path labeled $\alpha_{i+1} \cdots \alpha_p a$ follows for some $a \in \mathcal{A}$ and the other no such path exists, for $t(e_{\alpha_1} \cdots e_{\alpha_p}) \in \mathcal{V}(G_{Z_X})$ has no outer edges. Therefore, all the vertices in \mathcal{G}_{Z_X} represent different states in the Fischer cover of Z .

(2). By giving an example, we show that $X_V \& X_W$ depends on V and W and so on α and β . We construct our example from $X = X(S)$ an S -gap shift for $S = \{1, 2\}$ and Y a β -shift for $1_\beta = 1101$. First we recall the definitions of an S -gap and a β -shift.

An S -gap shift $X(S)$ is a coded system generated by $\{10^{s_i} : s_i \in S\}$ where $S \subseteq \mathbb{N} \cup \{0\}$. To define a β -shift, let β be a real number greater than 1 and set

$$1_\beta = a_1 a_2 a_3 \cdots \in \{0, 1, \dots, \lfloor \beta \rfloor\}^\mathbb{N},$$

where $a_1 = \lfloor \beta \rfloor = \max\{n \in \mathbb{N} : n \leq \beta\}$ and

$$a_i = \lfloor \beta^i (1 - a_1 \beta^{-1} - a_2 \beta^{-2} - \dots - a_{i-1} \beta^{-i+1}) \rfloor$$

for $i \geq 2$. The sequence 1_β is the expansion of 1 in the base β , that is, $1 = \sum_{i=1}^\infty a_i \beta^{-i}$. Let \leq be the lexicographic ordering of $(\mathbb{N} \cup \{0\})^\mathbb{N}$. The sequence 1_β has the property that

$$\sigma^k 1_\beta \leq 1_\beta, \quad k \in \mathbb{N}, \tag{3.4}$$

where σ denotes the shift on $(\mathbb{N} \cup \{0\})^\mathbb{N}$. It follows from (3.4) that

$$X_\beta = \{x \in \{0, 1, \dots, \lfloor \beta \rfloor\}^\mathbb{Z} : x_{[i, \infty)} \leq 1_\beta, i \in \mathbb{Z}\}$$

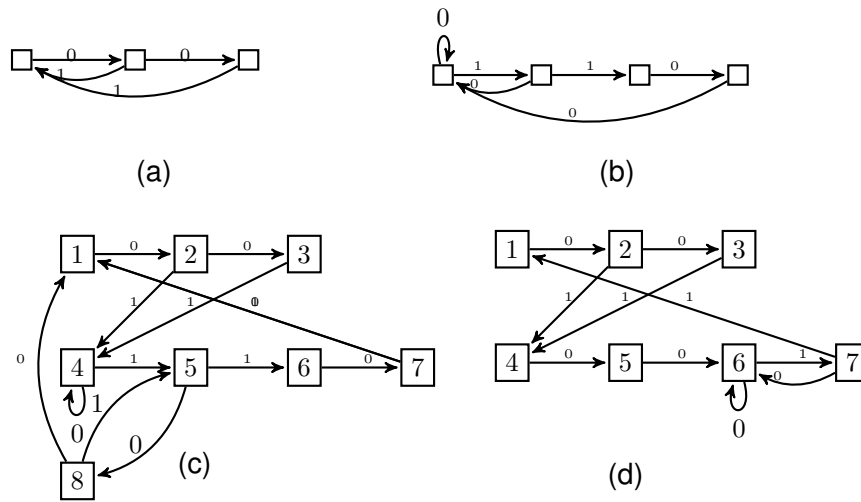

Figure 1: Fischer cover spaces of (a) S -gap shift for $S = \{1, 2\}$, (b) β -shift for $1_\beta = 1101$ and the cover for their intertwined systems (c) Z_1 and (d) Z_2 .

is a shift space of $\{0, 1, \dots, \lfloor \beta \rfloor\}^{\mathbb{Z}}$, called the β -shift (6). Their Fischer covers \mathcal{G}_X and \mathcal{G}_Y for $S = \{1, 2\}$ and $\beta = 1011$ is given in Figure 1. When $|S| < \infty$, then the S -gap shift is SFT (7, Theorem 3.3), and a β -shift is SFT if and only if the expansion of 1 in the base β is finite (8).

Therefore, our systems are SFT and it is obvious that 1 is a synchronizing word for X and 00, 100 are synchronizing words for Y . Let $V = \{01, 001\}$, $W_1 = \{u100 : 100u100 \in \mathcal{B}(Y), 100 \not\subseteq u\}$ and $W_2 = \{u11 : 11u11 \in \mathcal{B}(Y), 11 \not\subseteq u\}$. Then $X = X_V$ and $Y = Y_{W_1} = Y_{W_2}$. Let $Z_i = X \& Y_{W_i}$ and A_i be the adjacency matrix of \mathcal{G}_{Z_i} for $i = 1, 2$. Then

$$A_1 = \begin{bmatrix} 0 & 1 & 0 & 0 & 0 & 0 & 0 & 0 & 0 \\ 0 & 0 & 1 & 1 & 0 & 0 & 0 & 0 & 0 \\ 0 & 0 & 0 & 1 & 0 & 0 & 0 & 0 & 0 \\ 0 & 0 & 0 & 1 & 1 & 0 & 0 & 0 & 0 \\ 0 & 0 & 0 & 0 & 0 & 1 & 0 & 1 & 0 \\ 0 & 0 & 0 & 0 & 0 & 0 & 1 & 0 & 0 \\ 1 & 0 & 0 & 0 & 0 & 0 & 0 & 0 & 0 \\ 1 & 0 & 0 & 0 & 1 & 0 & 0 & 0 & 0 \end{bmatrix}, \quad A_2 = \begin{bmatrix} 0 & 1 & 0 & 0 & 0 & 0 & 0 & 0 \\ 0 & 0 & 1 & 1 & 0 & 0 & 0 & 0 \\ 0 & 0 & 0 & 1 & 0 & 0 & 0 & 0 \\ 0 & 0 & 0 & 0 & 1 & 0 & 0 & 0 \\ 0 & 0 & 0 & 0 & 0 & 1 & 0 & 0 \\ 0 & 0 & 0 & 0 & 0 & 0 & 1 & 0 \\ 0 & 0 & 0 & 0 & 0 & 0 & 1 & 1 \\ 1 & 0 & 0 & 0 & 0 & 0 & 1 & 0 \end{bmatrix},$$

with eigenfunctions p_1 and p_2 as,

$$p_1(x) = x^8 - x^7 - x^6 + x^5 - x^3 - 2x^2 - x, \quad p_2(x) = x^7 - x^6 - x^5 - x - 1$$

and the largest positive eigenvalues 1.6180 and 1.7 respectively. Hence, $h(Z_1) = \log 1.6180$ while $h(Z_2) = \log 1.7$. So Z_1 and Z_2 are not conjugate and in particular, the intertwined system of conjugate systems are not necessarily conjugate.

Theorem 3.3. *Let X and Y be two synchronized systems generated by $V = V_\alpha$ and $W = W_\beta$ as in (3.2). Then X and Y are sofic if and only if $Z = X \& Y = X_V \& Y_W$ is sofic.*

Proof. Let $X = X_V$ and $Y = X_W$ be two sofic systems and \mathcal{G}_X (resp. \mathcal{G}_Y) be the Fischer covers of X (resp. Y). Then \mathcal{G}_X^α and \mathcal{G}_Y^β and their intertwined cover \mathcal{G}_Z have finite vertices. But any symbolic system with a finite labeled graph is sofic and we are done.

For the converse suppose Z is sofic. Thus \mathcal{C}_Z , the set of follower sets of Z is finite. To prove the theorem, we will show that if $|\mathcal{C}_X| = \infty$, then $|\mathcal{C}_Z| = \infty$ which is a contradiction.

Fix $\alpha \not\subseteq u_1 \in \mathcal{B}(X)$ and let u_2 be any word in $\mathcal{B}(X)$ such that $F_X(u_1) \neq F_X(u_2)$. So let $v \in F_X(u_1) \setminus F_X(u_2)$ and first assume $\alpha \subseteq u_2$. Since α is a synchronizing word, $F_X(x'\alpha x) = F_X(\alpha x)$ for $x, x' \in \mathcal{B}(X)$. Hence, we may assume $u_2 = \alpha u'_2$. On the other hand for a $w_0\beta \in W_\beta$, $z_0 = \alpha w_0\beta$ is a synchronizing word for Z . Thus if v is a word in X and $v \notin F_X(\alpha u'_2)$ then $v \notin F_Z(z_0 u'_2)$; because, any path in \mathcal{G}_Z labeled z_0 is magic and $t(z_0 u'_2) \in \mathcal{G}_{Z_X}$. This in turn means that if there are infinitely many $u_2 = \alpha u'_2$ such that $F_X(u_1) \neq F_X(u_2)$, then there are infinitely many u'_2 such that $F_Z(u_1) \neq F_Z(z_0 u'_2)$.

If $\alpha \not\subseteq u_2$, then

$$F_X(u_2) = \bigcup_{\substack{\alpha u'_2 u_2 \in \mathcal{B}(X) \\ \alpha \not\subseteq u'_2 u_2}} F_X(\alpha u'_2 u_2).$$

But if $\alpha \not\subseteq w_2$ and $F_X(u_2) \neq F_X(w_2)$, then for some u'_2, w'_2 , $F_X(\alpha u'_2 u_2) \neq F_X(\alpha w'_2 w_2)$. So again an argument as above will show that the follower sets of Z is not finite.

If $\alpha \subseteq u_1$, then again we may assume $u_1 = \alpha u'_1$ and since $F_X(u_1) \subseteq F_X(u'_1)$, then we replace u'_1 with u_1 and will repeat the above argument. \square

Next example will illustrate the intertwining of two sofic systems X and Y .

Example 3.4. *Consider Figure 2 and two sofic shifts X and Y with $\alpha = \alpha_1 \alpha_2 = 00$ and $\beta = \beta_1 \beta_2 \beta_3 = 000$ as their synchronizing words respectively. The Fischer covers of X and Y are presented in that figure.*

First we will construct \mathcal{G}_X^α . We have $\mathcal{V}_{\mathcal{G}_X}(\alpha_1) = \{F_X(\alpha_1)\}$ and only $I = F_X(\alpha_1)$ needs in-splitting. We do this and we obtain $\mathcal{G}_X^\alpha = \mathcal{G}_{X_2}$.

For \mathcal{G}_Y^β , the first in-splitting occurs in $I = F_Y(\beta_{11})$. Do this in-splitting and call the new cover \mathcal{G}_{Y_2} . We have $\mathcal{V}_{\mathcal{G}_{Y_2}}(\beta_1 \beta_2) = \{F_Y(\beta_1)\}$ and $F_Y(\beta_1)$ needs also in-splitting. Doing this $\mathcal{G}_Y^\beta (= \mathcal{G}_{Y_3})$ will be constructed.

Definition 3.3 ((9)). A shift space X has *specification with variable gap length (SVGL)* if there exists $N \in \mathbb{N}$ such that for all $u, v \in \mathcal{B}(X)$, there exists $w \in \mathcal{B}(X)$ with $u w v \in \mathcal{B}(X)$ and $|w| \leq N$.

Note that a SVGL was called almost specified in (9).

Theorem 3.5. *Suppose X and Y are two synchronized systems generated by $V = V_\alpha$ and $W = W_\beta$ as in (3.2). Then $Z = X \& Y = X_V \& Y_W$ has SVGL if and only if $X = X_V$ and $Y = Y_W$ have SVGL.*

Proof. If $V = W$, then $Z = X$ and we are done. So suppose $W \neq V$ and pick $w_0\beta \in W \setminus V$.

First suppose Z has SVGL with the transition length M and suppose that one of X or Y , say X , does not have SVGL. Then for all n , there are $u_n, v_n \in \mathcal{B}(X)$ such that if $w \in \mathcal{B}(X)$ and $u_n w v_n \in \mathcal{B}(X)$, then $|w| \geq n$. Without loss of generality, assume that $\alpha u_n, v_n \alpha \in \mathcal{B}(X)$ for all n . Now let $z_n = \alpha w_0 \beta u_n$ and $z'_n = v_n \alpha w_0 \beta$ be the words in $\mathcal{B}(Z)$. Since Z has SVGL, there is $z''_n \in \mathcal{B}(Z)$ such that $z_n z''_n z'_n \in \mathcal{B}(Z)$ and $|z''_n| \leq M$ for all $n \in \mathbb{N}$. Note that this z''_n is a word such as $u'_n \alpha w_{i_1} \beta \cdots w_{i_k} \beta v'_n$ for some $u'_n, v'_n \in \mathcal{B}(X)$. Let $n > M$ and set $w = u'_n \alpha v'_n$. Then by the fact that α is a synchronizing word, $u_n w v_n \in X$ and $|w| \leq M$ which is absurd.

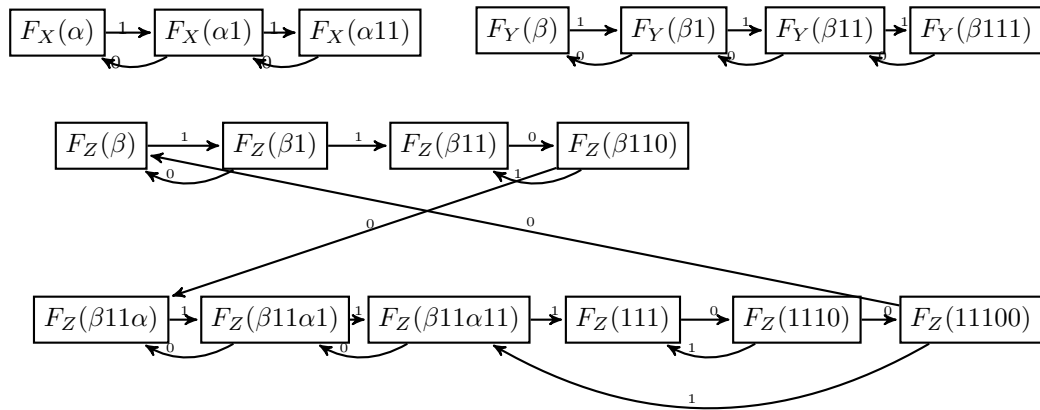

Figure 2: From above, the Fischer covers of X , Y and $Z = X \& Y$.

Now suppose both of X and Y have SVGL with the transition lengths M_X and M_Y . Let

$$m_1 = \min\{|\nu\alpha| : \nu\alpha \in V\} = |\nu_1\alpha|, \quad m_2 = \min\{|\omega\beta| : \omega\beta \in W\} = |\omega_1\beta|,$$

$$k = \max\{n \in \mathbb{N} : |n\alpha| < M_X\}, \quad l = \max\{n \in \mathbb{N} : |n\beta| < M_Y\},$$

and $M = M_X + km_2 + M_Y + lm_1$. We claim that M is a transition length for Z . Let $z_1, z_2 \in \mathcal{B}(Z)$. Different cases occur. We just prove two cases, other cases will be proved similarly. First case is when $z_1 = \gamma v_i \alpha w_j \beta z'$ and $z_2 = z'' \alpha w_p \beta \lambda$ where $\gamma, \lambda \in \mathcal{B}(Z)$ and $z', z'' \in \mathcal{B}(X)$ so that $\alpha \not\subseteq z', z''$. Since X has SVGL, there is $x = x_1 \alpha v_{i_1} \alpha \cdots v_{i_n} \alpha x_2$ such that $z' x z'' \in \mathcal{B}(X)$ and $|x| \leq M_X$. Then $z = x_1 \alpha w_1 \beta v_{i_1} \alpha w_1 \beta \cdots v_{i_n} \alpha w_1 \beta x_2 \in \mathcal{B}(Z)$ and $z_1 z z_2 \in \mathcal{B}(Z)$. Furthermore, $|z| \leq M_X + km_2 \leq M$.

The other case is when z_1 is as above and $z_2 = z'' \beta v_q \alpha \lambda$ with $\beta \not\subseteq z'' \in \mathcal{B}(Y)$. Since X and Y have SVGL, there are $x \in \mathcal{B}(X)$ and $y \in \mathcal{B}(Y)$ such that $z' x \alpha \in \mathcal{B}(X)$, $\beta y z'' \in \mathcal{B}(Y)$ and $|x| \leq M_X, |y| \leq M_Y$. We can assume that x (resp. y) does not contain α (resp. β) as a subword. Then $z_1 x \alpha y z_2 \in \mathcal{B}(Z)$. Note that $|x \alpha y| \leq M_X + m_1 + M_Y \leq M$ and we are done. \square

Recall that when X is a sofic shift space with non-wandering part $R(X)$, we can consider the shift space

$$\partial X = \{x \in R(X) : x \text{ contains no words that are synchronizing for } R(X)\}$$

which is called the *derived shift space* of X . An irreducible sofic shift space X is *near Markov* when it is AFT and its derived shift space ∂X is a finite set (10).

Theorem 3.6. *Let X and Y be two synchronized systems with $V = V_\alpha$ and $W = W_\beta$ generators for X and Y as in (3.2). If $Z = X \& Y = X_V \& Y_W$ is SFT, near Markov or AFT, then both X and Y are SFT, near Markov or AFT respectively.*

Proof. Suppose Z is SFT but X is not SFT. By Theorem 3.3, X is sofic and so ∂X is also sofic (10, Theorem 6.6). Thus there is a periodic point $p^\infty \in \partial X$ and let p be primitive. By the definition, α is not a subword of p^∞ . Also by Lemma 3.8, either there are two cycles in G_X labeled p or one

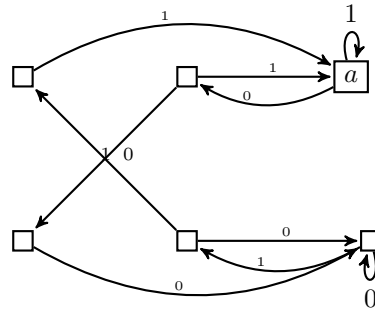

Figure 3: The Fischer cover of a non-AFT intertwined system, constructed from two AFT systems: two different paths labeled $(01)^\infty 111$ terminate at vertex a .

cycle consisting of concatenations of at least two paths labeled p . By Remark 3.1(1), G_{Z_X} is follower-separated, and this means the word p is not a synchronizing word which implies that $p^\infty \in \partial Z$ and so $\partial X \subseteq \partial Z$. By the same reasoning, $\partial Y \subseteq \partial Z$ and so

$$\partial X \cup \partial Y \subseteq \partial Z. \tag{3.5}$$

First suppose Z is SFT and one of X or Y , say X , is not SFT. Then $\partial X \neq \emptyset$ however $\partial Z = \emptyset$. So X is SFT.

Now suppose X is not AFT. So there are two different infinite paths $x = \dots e_{-1}e_0$ and $x' = \dots e'_{-1}e'_0$ with the same label and $t(e_0) = t(e'_0)$. If $\alpha \not\subseteq \mathcal{L}_{X_\infty}(x) = \mathcal{L}_{X_\infty}(x')$, then x and x' will be two paths in G_Z where $\mathcal{L}_{Z_\infty}(x) = \mathcal{L}_{Z_\infty}(x')$ and terminating at the same vertex of $\mathcal{V}(G_Z)$. So Z is not AFT which is absurd. Otherwise, since α is a synchronizing word and so magic for \mathcal{G}_X , we may assume $\mathcal{L}_X(e_{-(|\alpha|-1)} \dots e_{-1}e_0) = \alpha$ and by the proof of Theorem 3.3, both of these paths terminate at the same vertex. By technique of merging (1, Section 3.3), one can obtain the Fischer cover of Z from \mathcal{G}_Z . However, two vertices of \mathcal{G}_Z merge only if one in $\mathcal{V}(G_{Z_X})$ and the other is in $\mathcal{V}(G_{Z_Y})$. Hence after merging, x and x' will be yet two different paths with the same label and terminating at the same vertex. This means Z is not AFT which is absurd.

If Z is near Markov, then it is AFT and $|\partial Z| < \infty$. So X and Y are near Markov if ∂X and ∂Y are finite which is a consequence of (3.5). \square

The converse in Theorem 3.6 does not hold necessarily. We will give an example of X and Y , both AFT, in fact SFT, such that $X_V \& Y_W$ is not AFT for some set of generators V and W .

Example 3.7. Let $S = S' = \{0, 1, 2\}$, $X = X(S)$ and take Y to be the set of binary sequences whose runs of 1's is restricted to S' . Choose $\alpha = 00$ and $\beta = 11$ to be the synchronized words for defining the generating sets V and W respectively. The Fischer cover of $X \& Y = X_V \& Y_W$ is as in Figure 3. Observe that there are two different infinite paths terminating at the same vertex a and having the same label $(01)^\infty 111$. Therefore, $X \& Y$ is not AFT.

Now we give sufficient conditions such that the converse of Theorem 3.6 holds. Suppose X is a sofic shift with the Fischer cover $\mathcal{G} = (G, \mathcal{L})$. Let $G^\#$ be a new graph whose vertex set is the set $2^\mathcal{V}$ of subsets of the vertex set \mathcal{V} of G . Let \mathcal{A} be the alphabet of X . We draw an arrow labeled $a \in \mathcal{A}$ from a subset $F \in 2^\mathcal{V}$ to another subset $F' \in 2^\mathcal{V}$, when

$$F' = \{x \in \mathcal{V} : \text{there is an edge labeled } a \text{ from an element of } F \text{ to } x\}.$$

We denote this new labeled graph by $(G^\#, \mathcal{L}^\#)$. By (10, Proposition 6.5), $\partial X = \mathcal{L}^\#_\infty(X_{G^\#})$ where $G^\#$ denotes the subgraph of $G^\#$ obtained by erasing all vertices $F \in 2^V$ for which $\#F \neq 2$, together with all arrows to or from such a vertex.

Lemma 3.8. *Let X be a sofic shift with the Fischer cover $\mathcal{G} = (G, \mathcal{L})$. Also let $x = p^\infty \in \partial X$ where p is primitive and let $p = \mathcal{L}(\pi_0)$ for some path π_0 in G . If there is only one cycle γ in G such that $x = \mathcal{L}_\infty(\gamma^\infty)$, then γ consists of concatenations of at least two paths labeled p .*

Proof. Let $p = p_0 p_1 \cdots p_{n-1}$. Then there is a cycle $\lambda = e_0 e_1 \cdots e_{n-1}$ in $G^\#$ such that $\mathcal{L}^\#(\lambda) = p$. Also suppose the edge e_i , $0 \leq i \leq n-1$ starts from the vertex $\{I_i, J_i\}$ and terminates at $\{I_{(i+1) \bmod n}, J_{(i+1) \bmod n}\}$. Note that if $e \in \mathcal{E}(G^\#)$ starts from $\{K_1, L_1\}$ and terminates at $\{K_2, L_2\}$, since $K_i \neq L_i$ for $i = 1, 2$, e represents two different edges e_1 and e_2 in G such that $i(e_i) \in \{K_1, L_1\}$ and $t(e_i) \in \{K_2, L_2\}$. So there are two paths π_1 and π_2 in G such that $\mathcal{L}(\pi_i) = \mathcal{L}(\pi_0) = p$ and

$$i(\pi_i), t(\pi_i) \in \{I_0, J_0\}, \quad i = 1, 2. \tag{3.6}$$

Suppose there is only one cycle γ in G such that $x = \mathcal{L}_\infty(\gamma^\infty)$. Since $I_0 \neq J_0$, I_0 and J_0 are different vertices along γ and by (3.6), they are initial and terminating points for two different paths in G labeled p and we are done. \square

An immediate consequence of the above lemma is that if $x = p^\infty \in \partial X$, then there are two different paths π_1 and π_2 with $\mathcal{L}(\pi_i) = p$ for $i = 1, 2$ and either both are in a cycle γ or in the different cycles γ and γ' such that

$$p^\infty = \mathcal{L}_\infty(\gamma^\infty) = \mathcal{L}_\infty(\gamma'^\infty). \tag{3.7}$$

Lemma 3.9. *Suppose \mathcal{G} is a finite right-resolving labeled graph with two different paths $\xi = \cdots e_{-1} e_0$, $\xi' = \cdots e'_{-1} e'_0$ and $\mathcal{L}(e_i) = \mathcal{L}(e'_i)$. Then there are two different cycles $C_\xi = e_{-m} \cdots e_{-n}$ and $C_{\xi'} = e'_{-m} \cdots e'_{-n}$ in \mathcal{G} .*

Proof. Without loss of generality assume that $t(e_0) \neq t(e'_0)$. Otherwise, there must be e_ℓ such that $t(e_\ell) \neq t(e'_\ell)$ and we will do our argument for paths $\eta = \cdots e_{-\ell-1} e_\ell$ and $\eta' = \cdots e'_{-\ell-1} e'_\ell$.

There is at least one vertex v in G such that ξ meets it infinitely many often. Let $v = t(e_{-i_j})$ for $j \in \mathbb{N}$ and choose $j_m > |\mathcal{V}_G|$. Also let v'_j be the terminating vertex for e'_{-i_j} . We follow ξ and ξ' (backward) and simultaneously. Thus by pigeon principle, at least two vertices v'_{j_1} and v'_{j_2} amongst the j_m vertices v'_1, \dots, v'_{j_m} are equal and let $v' = v'_{j_1} = v'_{j_2}$. This means that when v' returns to itself along ξ' , v returns to itself along ξ and so ξ and ξ' have met at least a cycle simultaneously on their ways. Call the cycles $C_\xi = e_{-m} \cdots e_{-n}$ and $C_{\xi'} = e'_{-m} \cdots e'_{-n}$ respectively. Note that $C_\xi \neq C_{\xi'}$. Otherwise, since $t(e_0) \neq t(e'_0)$, there is a vertex $w = t(e_k)$ for some $-n \leq k \leq -1$ with two different outer edges labeling the same which violates the fact that \mathcal{G} is right-resolving. \square

Theorem 3.10. *Let X and Y be two synchronized systems generated by $V = V_\alpha$ and $W = W_\beta$ as in (3.2) and $P_n(X) \cap P_n(Y) = \emptyset$ for all $n \in \mathbb{N}$ where $P_n(X)$ denotes the set of periodic points in X of period n . If $X = X_V$ and $Y = Y_W$ are SFT, AFT or near Markov, then $Z = X \& Y = X_V \& Y_W$ is SFT, AFT or near Markov, respectively.*

Proof. Suppose X and Y are SFT but Z is not so. Then $\partial X = \partial Y = \emptyset$ while $\partial Z \neq \emptyset$. Since ∂Z is a sofic subsystem of Z , there is a periodic point $p^\infty \in \partial Z$.

First suppose $\beta v \alpha \not\subseteq p^\infty$, for any $v \alpha \in V$. By the hypothesis, this means that either $p^\infty \in \mathcal{G}_{Z_X}$ or $p^\infty \in \mathcal{G}_{Z_Y}$. Suppose the former happens. Thus $\alpha \not\subseteq p^\infty$. Now choose m sufficiently large so that p^m is a synchronized word in X and $p^m \notin \mathcal{B}(Y)$. The existence of such m is guaranteed by the fact that X is SFT and $p^\infty \notin Y$. To have a contradiction, we show that p^m is a synchronized word for Z . So let $u p^m$ and $p^m w$ be arbitrary words for Z . Since $p^m \notin \mathcal{B}(Y)$, $u = u_1 u'$ and $w = w' w_1$ where $u', w' \in \mathcal{B}(X)$ and they do not have α as a subword. We are trivially done if u_1 or w_1 is an

empty word. Otherwise, without loss of generality assume $u_1 = \beta$ and $w_1 = \alpha$. Therefore, $\beta u' p^m$ and $p^m w' \alpha$ are in X and this implies $\beta u' p^m w' \alpha \in \mathcal{B}(X)$ and we are done.

Now suppose $\beta v \alpha \subseteq p$. Then $p = v_{i_1} \alpha w_{j_1} \beta \cdots v_{i_k} \alpha w_{j_k} \beta$ where $v_{i_r} \alpha \in V$ and $w_{i_r} \beta \in W$, $1 \leq r \leq k$. Without loss of generality assume that $p = v \alpha w \beta$ and let $V' = \{v : v \alpha \in V\}$, $W' = \{w : w \beta \in W\}$. If $v \notin V'$ (resp. $w \notin W'$), then $\beta v \alpha$ (resp. $\alpha w \beta$) is a synchronized word for Z and $p^\infty \notin \partial Z$. So $v, w \in V' \cap W'$ and by the definition of our generators

$$\alpha, \beta \not\subseteq v, \quad \alpha, \beta \not\subseteq w. \tag{3.8}$$

By Lemma 3.8, there are two different paths π_1 and π_2 in G_Z with $\mathcal{L}_Z(\pi_i) = p$ for $i = 1, 2$ and either both are in a cycle γ or in different cycles γ and γ' such that 3.7 holds. Consider the following cases.

1. There are more than one cycle. Then (3.7) implies that $(v \alpha w \beta)^\infty = (v \beta w \alpha)^\infty$. By (3.8), either $v = w$ or $\alpha = \beta$. Considering the fact that any path labeled $v \alpha \in V$ (resp. $w \beta \in W$) terminates to the same vertex, the former will not allow \mathcal{G}_Z being right-resolving and the latter contradicts our hypothesis $P_n(X) \cap P_n(Y) = \emptyset$ for all n .
2. There is only one cycle γ with $p^\infty = \mathcal{L}_{Z^\infty}(\gamma^\infty)$. Then the label of this unique cycle γ must be $v \alpha w \beta$. But by Lemma 3.8, this cycle must be formed from the concatenation of at least two paths with the same label and (3.8) implies that in our situation $v \alpha = w \beta$ and this in turn implies $P_n(X) \cap P_n(Y) \neq \emptyset$ for some n .

As a result, $\partial Z = \emptyset$ and Z is SFT.

Suppose X and Y are AFT but Z is not AFT. So there are two different paths $\xi = \cdots e_{-1} e_0$ and $\xi' = \cdots e'_{-1} e'_0$ in G_Z with the same label and terminating at the same vertex. Also we may assume $e_0 \neq e'_0$ and let $C_\xi = e_{-m} \cdots e_{-n}$ and $C_{\xi'} = e'_{-m} \cdots e'_{-n}$ be two different cycles provided by Lemma 3.9.

1. If C_ξ (resp. $C_{\xi'}$) is a cycle in G_{Z_X} (resp. G_{Z_Y}), then

$$(\mathcal{L}(e_{-m} \cdots e_{-n}))^\infty = (\mathcal{L}(e'_{-m} \cdots e'_{-n}))^\infty \in P_{n+m}(X) \cap P_{n+m}(Y)$$

violating our hypothesis.

2. If C_ξ and $C_{\xi'}$ are both cycles in G_{Z_X} , then we may assume that $t(e_0) = t(e'_0) = I_\beta$; otherwise, we may continue ξ and ξ' on a common path to get to I_β . But then we will have two different infinite paths labeled the same and terminating at the same vertex in \mathcal{G}_X violating the fact that \mathcal{G}_X^α is left closing by Theorem 3.2.
3. Note that in (1) and (2), $\mathcal{L}(C_\xi) = \mathcal{L}(C_{\xi'})$ does not have α or β as its subword. So the remaining case is that when $\alpha, \beta \subseteq \mathcal{L}(C_\xi)$. This implies $\mathcal{L}(C_\xi) = \mathcal{L}(C_{\xi'}) = w_{i_1} \beta v_{j_1} \alpha \cdots \alpha$. Let π_{i_1} and π'_{i_1} be the subpaths of C_ξ and $C_{\xi'}$ such that $\mathcal{L}(\pi_{i_1}) = \mathcal{L}(\pi'_{i_1}) = w_{i_1}$. The fact that \mathcal{G}_Z is right-resolving and paths labeled α terminate at the same vertex, implies that $\pi_{i_1} = \pi'_{i_1}$. By the same reasoning, paths in C_ξ and $C_{\xi'}$ labeled v_{j_1} are identical and carrying out this reasoning for all the subpaths of C_ξ and $C_{\xi'}$ we will have $C_\xi = C_{\xi'}$ which is absurd.

Now let X and Y be near Markov. So they are AFT and $|\partial X|, |\partial Y| < \infty$. Moreover, Z is AFT. If $|\partial Z| = \infty$, then since ∂Z is sofic there will be infinitely many periodic points in ∂Z . Apply the same reasoning as in the SFT – for the second part where $\beta v \alpha \subseteq p$ – to see that for any $p^\infty \in \partial Z \setminus (\partial X \cup \partial Y)$, we will have a contradiction. Thus $\partial Z \subseteq (\partial X \cup \partial Y)$ and we are done. \square

Competing Interests

The authors declare that no competing interests exist.

References

- [1] Lind D. Marcus B. An Introduction to Symbolic Dynamics and Coding, Cambridge Univ. Press; 1995.
- [2] Moon J. Brickner B. Maximum transition run codes for data storage systems, IEEE Trans. Magn, 1996; 32:3992-3994.
- [3] Blanchard F. Hansel G. Systèmes codés, Comp. Sci, 1986; 44: 17-49. French.
- [4] Nasu M. An invariant for bounded-to-one factor maps between transitive sofic subshifts, Ergod. Th. & Dynam. Sys, 1985; 5: 89-105.
- [5] Fiebig D. Fiebig U. Covers for coded systems, Contemporary Mathematics, 1992; 135: 139-179.
- [6] Thomsen K. On the structure of a sofic shift space, Comp. Sci, 2004; 9: 3557-3619.
- [7] Ahmadi Dastjerdi D. Jangjoo S. Dynamics and topology of S -gap shifts, Topology and its Applications, 2012; 159: 2654-2661.
- [8] Bassino F. Beta-expansions for cubic Pisot numbers, Theoretical Informatics (Cancun), Lecture Notes in Comput. Sci 2002; 2286: 141-152.
- [9] Jung U. On the existence of open and bi-continuing codes, Trans. Amer. Math. Soc, 2002; 363: 1399-1417.
- [10] Thomsen K. On the structure of β -shifts, Contemp. Math, 2005; 385: 321-332.

©2014 D. Ahmadi Dastjerdi & S. Jangjooye Shaldehi; This is an Open Access article distributed under the terms of the Creative Commons Attribution License <http://creativecommons.org/licenses/by/3.0>, which permits unrestricted use, distribution, and reproduction in any medium, provided the original work is properly cited.

Peer-review history:

The peer review history for this paper can be accessed here (Please copy paste the total link in your browser address bar)

www.sciencedomain.org/review-history.php?iid=439&id=6&aid=3745