



A Review of Soil Dynamics in Traction Studies

A. M. Sedara^{1*}

¹*Department of Agricultural and Environmental Engineering, The Federal University of Technology, Akure, Nigeria.*

Author's contribution

The sole author designed, analysed, interpreted and prepared the manuscript.

Article Information

DOI: 10.9734/JERR/2019/v4i416912

Editor(s):

(1) Dr. Qing Li, College of Mechanical Engineering, Donghua University, Shanghai, China And Department of Mechanical Engineering, University of Alberta, Edmonton, Canada.

Reviewers:

(1) Şükrü Kitiş, Dumlupınar University, Turkey.

(2) Dr. S. Suppiah, Institute of Science and Technology, India.

Complete Peer review History: <http://www.sdiarticle3.com/review-history/48552>

Review Article

Received 05 February 2019

Accepted 17 April 2019

Published 01 May 2019

ABSTRACT

As the world population increases more than ever before and increasing demand on food, feed and fiber, and security, the number of off-the-road vehicles is rapidly increasing for agriculture, forestry, military, mining and construction industries. Many researchers have studied and still investigating traction as it relates off-road vehicles and publications abound especially from developed countries of Europe, America and others. In our generation scientists are trying to put robotic vehicles on the lunar and Martian terrains. This trend makes the study of soil dynamics in traction a sine qua non in our tertiary and research institutions. In Nigeria there is a dearth of publications in this specialized area of study. This is a review paper and the purpose is to highlight some of the studies that have been conducted over the years, with a view to enlightening, encouraging, stimulating and challenging would be researchers. Trends in the development of soil bin with single wheel testers were reviewed including tractive and transport devices used in them. Traction parameters including motion resistance, measurement and data acquisition systems, traction predictive equations including wheel numeric and mobility numbers were also reviewed. Efforts made in the development of soil bin for soil dynamics research and further research interest at the Federal University of Technology, Akure (FUTA) were highlighted.

Keywords: *Soil dynamics; traction; motion resistance; traction parameters; prediction equations.*

*Corresponding author: Email: adewale.sedara@gmail.com;

1. INTRODUCTION

To an agricultural engineer soil may be defined as a loose (unconsolidated) heterogeneous three-phase mineral or organic matter surface of the earth's crust that is capable of supporting growth of plant. [1] defines soil as unconsolidated mineral matter on the surface of the earth that has been subjected to and influenced by genetic and environmental factors of parent material, climate (including moisture and temperature effects) micro and macro-organisms and topography, all acting over a period of time and producing a product-soil that differs from the material from which it is derived in many physical, chemical and biological properties and characteristics. According to Culpin [2], agricultural soils consist mainly of a heterogeneous collection of mineral particles existing either singly or as small 'crumbs' comprising several particles grouped together. Between soil particles are spaces which may be filled by air or by water.

Due to the high and increasing global population, the demand for more food feed and fiber will continue to be on the increase. This demand will call for higher level of agricultural mechanization and corresponding increase in size of agricultural machinery. Increasing weight of agricultural machinery is not without its negative side effects which is soil compaction. Soil compaction retards crop germination, growth and yield. It decreases water infiltration into the soil and increases surface water runoff and erosion. This type of soil degradation is also common with the use of forestry machinery and off- the road military equipment. In order to make the soil serve man sustainably, the study of soil dynamics in traction is *sine qua non*.

Terrain may be defined as a stretch of land, especially with regard to its physical and/or natural features. Traction can also be defined as the ability of vehicle's tractive element to generate enough forces/thrust to overcome all types of vehicle resisting forces and hence keep the vehicle in constant travel [3]. The study of interaction of terrain with machine usually called soil-machine interaction can be classified into two [4]: Interaction of the soil and the tractive element e.g. wheel or track; interaction of the soil with tools e.g. tillage tools, planters, fertilizer applicators, harvesting tools and other soil-engaging tools. The first is known as traction studies while the second is called tillage studies. In traction studies, interaction between vehicle and terrain is achieved through the running gear

system, which produces reaction and responses at the terrain interface. The greater the ability of the terrain material and the interactions at the interface to transfer the thrust action into the substrate, the better the capacity of the vehicle to achieve maximum tractive efficiency [3].

For optimum mobility to occur, it is required that the vehicle be able to move from one point to another with minimum amount of motion loss and energy input. To achieve this, the terrain must provide floatation as well as resistance capability such that enough thrust can be developed between the running gear contact element and terrain material itself with minimal wheel slippage.

Soil dynamics in traction is significant in all off-road vehicles soil- wheel interaction both for Agriculture, Forestry and Military off- road vehicles. According to Zoz and Grisso [5], the basic problems and concerns in the study of vehicle traction mechanics revolve around the need to: establish a better knowledge and insight into the mechanics of interaction between vehicle tractive elements and the material surface over which they act; develop a rational means for evaluating the performance of the tractive elements over specific terrain conditions; provide the mathematical or computational models of performance of the tractive elements thus leading to implementation of optimization procedures; establish the basic means for determination of the capability of a vehicle to move from one location to another. The major goal of researcher in the field of off-road traction mechanics as it applies to agricultural field operation is to understand and predict the performance of tractors. Zoz and Grisso [5] reported that tractor performance is influenced by traction elements, soil conditions, implement type and tractor configuration and that efficient operation of farm tractors includes: maximizing the fuel efficiency of the engine and drive train; maximizing the tractive advantage of the tractive devices and selecting an optimum travel speed for a given tractor-implement system. The understanding and prediction of tractor performance has been a major goal of many researchers. Tractor performance is influenced by traction elements, soil conditions, implement type, and tractor configuration [6].

2. DEVELOPMENTS IN TRACTION SOIL BINS AND SINGLE WHEEL TESTERS

Freitag [7] studied the performance of pneumatic tires on sand. The tire-soil tests were conducted

with single-wheel dynamometer and soil-bin system in the facilities of the Mobility Research Branch of the U.S. Army Engineer Waterways Experiment Station (WES). Upadhyaya et al. [8] developed a unique, mobile, single wheel traction testing device at the Department of Agricultural Engineering, University of California, Davis. It was essentially a mobile soil bin that could be used to conduct controlled field experiments in situ. The device was used to test tires ranging in diameter from 0.46 m (rim ID) to 2 m (OD) and up to maximum tire width of 1.0 m. The system was designed to provide an infinitely variable vertical load up to a maximum of 26.7 kN and a draft load up to a maximum of 13.3 kN.

Patel and Godwin [9] carried out a study on controlled soil bin tests for pneumatic tires. In the study, a single wheel test bed (Fig. 1) was developed for performing wheel-soil interaction study at heavy wheel loads under controlled environment. The tests were performed on soft and hard surfaces characterized by soil and concrete respectively on the soil bin.

Yahya et al. [10] carried out a study on a long soil bin to study tire traction facility (Fig. 2). This study spearheads fundamental research on traction mechanics with high-lug agricultural tires on tropical soils was designed and developed. The developed facilities consist of a moving carriage with a cantilever-mounted tire that moves in either forward or reverse directions on wall rails above a soil tank. The facility set-up was able to operate in either: (a) towing test mode for tire motion resistance studies or (b) driving test mode for tire net traction and tractive

efficiency studies. The test tire on the moving carriage under the towing test mode was to operate and engage onto the soil surface in the tank through a chain drive system. Under the driving test mode, the test tire on the moving carriage was powered to rotate by a motor and a gearbox system with an additional pull provided by a cable-pulley mechanism connected to a tower with hanging dead weights. The long soil bin however results in testing high lug agricultural tires at towed and driving modes for their motion resistance, net traction and tractive efficiency at different soil conditions. The facility can also be used for testing the effects of other parameters such as dynamic loading, ballasting and travel speed and tire inflation pressure on tractive performances of the tire.



Fig. 1. Off road dynamic facility – soil bin [9]

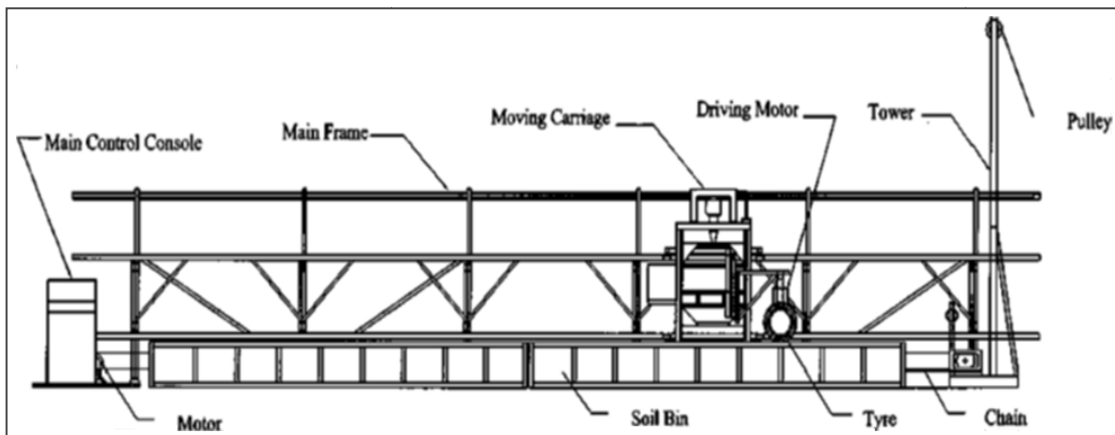

Fig. 2. Schematic diagram of a long soil bin for tire traction testing facility [10]

Taghavifar and Mardani [11] carried a study on contact area determination of Agricultural tractor wheel with soil. In the study, an experimental test was conducted inside a soil bin facility providing entirely reliable and controlled condition for the test. The test had the advantage of utilizing images taken of the contact areas and subsequently, using a planimeter to obtain the values of contact area precisely. Test variables that were the two most prominent and influential

parameters were tire inflation pressure and vertical load applied on wheel. Similarly, [12] carried out a study on evaluation and measurement of the performance parameters of agricultural wheels. In the study, a single-wheel tester (Fig. 3) was designed, constructed and evaluated inside a soil bin. The tested wheel was directly driven by the electric motor. Vertical load was applied by a power bolt on wheel. This tester could measure required draft force, the

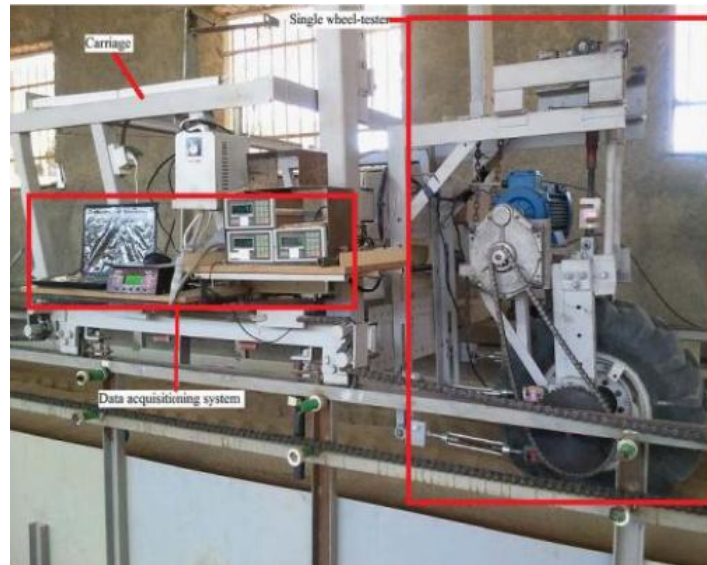

Fig. 3. The general overview of the testing facility [12]



Fig. 4. Test rig coupled to the tractor during field test
1. Test wheel 2. Load hanger 3. Load 4. The BFG 5. Three-point hitch frame 6. Connecting cable 7. Notebook PC [13]



Fig. 5. General view of a single-wheel tester inside soil bin facility [14]

Table 1. Some single wheel tester used in soil bins and in the field (a) In soil bins (b) In the field

Institution	Range of wheel diameter (mm)	Max dynamic load, kN	References
USDA-ARS-NSDL (Auburn, Alabama)	1265 - 1880	44	[15,16]; [17]
University of Kentucky, Lexington, Ky	- 745 max.	9.8	[18,19,20,21].
Carleton University, Ottawa, Ontario, Canada	-1200	11.2	[22]
Technical University of Munich, Munich, Germany	500 -1200	Using Dead weights	[23]
Cranfield University at Silsoe, Silsoe Bedfordshire, U. K	500 - 1400	123 Through hydraulic cylinders	[24]
(b) Single wheel tester used in the field			
USDA-ARS-NSDL (Auburn, Alabama)	1261 - 2180	66	[25]
University of California, Davis	460 - 2500	27	[8]
Silsoe Research Institute, Silsoe Bedfordshire, U. K	1200 - 1760	27	[26,27,28]
DERA (QinetiQ Ltd) Farmborough, Hampshire, U.K	-- --	55 Using Dead weights	[29,30].
Technion- Israel Institute of Technology, Haifa, Israel	-- 2000	50	[31,32]

depth of tire sinkage, contact area between wheel and soil, and soil stress at different depths both alongside and perpendicular to the direction of traversing. In order to evaluate the system performance, traction force was measured by the connected S-shaped load cell at arms between the wheel-tester and carriage.

Ahmad et al. [13] reported a motion resistance rig (Fig. 4) that was designed to measure the towing force of a single test wheel towed by a tractor. Taghavifar and Mardani [14] reported on single wheel tester (Figs. 5 and 6) at the Department of Agricultural Machinery of Urmia University, Iran to study the effects of slippage, velocity and wheel load on net traction.

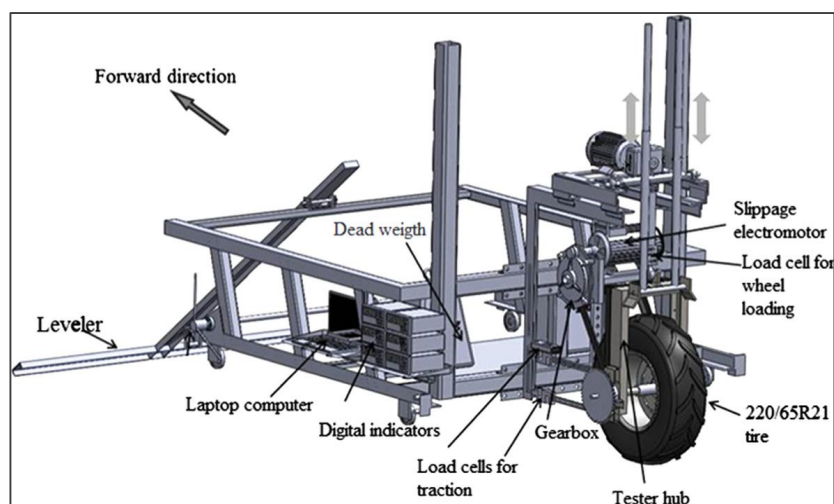

Fig. 6. Schematic of the utilized single-wheel tester along with its detailed components [14]

Some other single wheel testers in the soil bins and in the field are presented in Table 1.

3. MOTION RESISTANCE AND MEASUREMENT

According to Ahmad et al. [13], motion resistance can be regarded as the total drag opposite to the steady motion of a free motion wheel across a horizontal surface. To them, it can also be defined as integral of the horizontal component of the radial stresses. Motion resistance refers to the resistance to motion of a wheel caused by the absorption of energy in the contacting surfaces of the wheel and the soil upon which the wheel rolls. The motion resistance may be expressed as reported by Ahmad et al. [13] in Eq. (1).

$$MR = MR_c + MR_b + MR_t \quad (1)$$

The total motion resistance force, MR is made up of the MR_c , the component due to soil compaction, MR_b , the component due to horizontal soil displacement and MR_t , the component due to flexing of the tire. For vehicle operating on a hard surface, MR_t constitutes the largest percentage of the motion resistance force and this, can be slightly reduced by increasing the inflation pressure and the effective stiffness of the tire. In off-road situations, however, the components MR_c and MR_b make up the largest proportion of the motion resistance force and increasing the inflation pressure and the tire stiffness have shown to increase the motion resistance [33].

Usually, the motion resistance is expressed in terms of motion resistance ratio (τ).

Mathematically, the motion resistance ratio is as expressed as shown in Eq. (2).

$$MMR(\tau) = \frac{MR}{W} \quad (2)$$

where MR is the motion resistance force suffered by the wheel and W is the normal load on the wheel.

The performance characteristics of a towed wheel are described usually by a towing force (motion resistance), sinkage and skid. The most pertinent parameter of the towed pneumatic wheel is the motion resistance, which is influenced by the tire design, system parameters and terrain characteristics. In studying the soil-wheel interaction, the behavior of the soil and the most important design parameters of the wheel form the basic inputs [34].

Traditionally, design parameters of the tire include diameter of the wheel, section width, section height, inflation pressure and load deflection relationship. All these are considered to have varying degree of influence on the tire soil interaction. The terrain characteristics include the types of soil, soil moisture content and its compaction level and the system parameters comprise the dynamic (normal) load on the wheel and forward speed. The dynamometer reading is usually always taken to determine the towing force.

4. TRACTION

Traction may be defined as the force derived from the interaction between a device and a medium that can be used to facilitate a desired

motion over the medium [35]. Net traction, can be defined [36] as the force parallel to the direction of travel, developed by the traction device and transferred to the vehicle. Gross Traction is the sum of net traction and motion resistance.

Tractive effort developed by off-road vehicles has been of interest to people engaged in agricultural, forestry, military and mining operations. Most research conducted in off-road traction mechanics has focused on either agricultural or military equipment [37].

Tractive performance is affected by both the soils' normal strength and its shear strength. In general, normal strength has the most effect on motion resistance, while shear strength has the most effect on travel reduction. Describing and documenting the soil is perhaps the most difficult part of traction testing. There are several reasons for the difficulty. First, the soil has sufficient variation, which can easily influence the soil sampling device. Second, soil measurements are time consuming, and finally, the sampling technique may not be replicated or repeated for different soil conditions. For this reason, much of the traction tests reported are of a comparative nature, that is, one traction device compared to another device while operated under the same soil conditions. The device that is the most portable and commonly used, the cone penetrometer, works well only if the soil has moisture and if it has not been disturbed. Soil strength as measured by the soil cone penetrometer provides a combined measurement of soil normal strength and shear strength. The cone penetrometer also requires a large number of measurements because there is a large variability in the test results.

4.1 Traction Parameters

According to Zoz and Grisso [5] five dimensionless parameters are used to describe tractive performance:

- Travel reduction ratio (TRR), commonly called "slip" and expressed in percent.
- Net traction ratio (NTR), sometimes called pull/weight ratio.
- Tractive efficiency (TE) usually thought of as percent but used as a ratio in this paper.
- Gross traction ratio (GTR).
- Motion resistance ratio (MRR).

The traction parameters involving forces are all normalized by dividing by W_d , the dynamic force

reaction supporting the wheel or traction device. W_d includes static axle weight and any weight transfer that might take place during the testing process, that is, the total reaction force. Dividing by W_d allows comparisons between tires and other tractive devices of different sizes and weights and provides a dimensionless parameter for traction comparisons. It is important to note that the above parameters apply to a traction device and not necessarily to a vehicle [5].

5. MEASUREMENT AND DATA ACQUISITION

Data acquisition and control computers and all the associated recording and display equipment are required to process data acquired during the conduct of test programs. In addition to coordinating data acquisition, the package may also provide computer control of the test units.

For effective work and utilization of soil bin in traction studies, commercially available measuring and recording equipment should be used where necessary. It is expected that as measurable parameters are identified, new measuring devices should be developed so that their importance in soil machine - relations can be determined by physical measurements. Direct access to instrument manufacturers, who share in the development of new measuring devices, provides an effective way of securing best designs. An overall goal of soil dynamics will permit manipulation of soil from an initial known condition into a new and specified condition; digging, cutting, loading and transport of soil in effective and efficient ways; attainment of adequate tractive forces in effective and efficient manners; mobility across terrain with a variety of conditions; and prediction of soil behavior under the action of dynamic loads applied by machines and vehicles [38].

The Data acquisition system for the test facility is usually located on a special place on the carriage close to the soil bin facility. This dedicated system is made up of some sensor outputs interfaced to a computer system. The computer system can receive, monitor, display and store the measured signals from the respective transducers. AC program is used to retrieve and read the stored data and compute average, standard deviation and variance of the needed tire performance measurements. An optic tachometer that is located on the main drive shaft of the carriage driving unit measures the moving carriage speed. This unit can detect revolutions

in digital values without making direct contact. In detecting revolutions, the optic tachometer senses the special color sign that is located on the revolving shaft and detects signals equals to the numbers of the revolution of the rotating main drive shaft. A notebook may be used for data acquisition system, monitoring and real time control of the system. In any mode, data acquisition system may perform at different sampling rates. The display of data is available to user at real time on the computer monitor screen and the data could be permanently stored in a defined file in the computer [39].

6. TRACTION PREDICTION EQUATIONS

According to Upadhyaya [40] numerous attempts have been made to quantify soil-traction device interaction. These attempts can be classified under the following three broad categories: (1) analytical methods; (2) semi-empirical, parametric or analog methods; and (3) empirical methods.

6.1 The Analytical or Theoretical Approach

The analytical or theoretical approach assures a certain level of understanding of the basic process [41]. In order to predict the performance of a traction device, we need to know the distribution of normal and shear stress at the soil-tire/track interface and the geometry of the 3-D contact surface. Wulfsohn [42] has provided an extensive review of soil-wheel interaction surface geometry and distribution of stresses at the soil-traction device interface.

6.2 The Semi-empirical or Parametric Approach

The semi-empirical or parametric approach utilizes two analog devices to represent soil-traction device interaction. Vertical deformation of the soil under load is assumed analogous to soil deformation under a flat plate. The shear deformation of the soil under a traction device is assumed to be similar to the shear due to a torsional shear device or a rectangular grouser unit. The normal stress under a flat plate is assumed to be of the form [43] and [44];

$$P = \left(\frac{K_c}{b} + K_\phi \right) z^n \quad (3)$$

where P is normal pressure under the plate, b is minimum dimension of a rectangular plate; the diameter for a circular plate, z is soil deformation and K_c , K_ϕ and n are soil parameters

Although several different expressions are available to relate shear stress to soil deformation [43,45] and [3], the [46], [47] relationship is most widely used in agriculture:

$$\tau = \tau_{\max} \left(1 - e^{-j/k} \right) \quad (4)$$

where τ is shear stress,

$\tau_{\max} = c + p \tan \phi = \text{max shear stress}$,

$$\tau_{\max} = c + \sigma \tan \phi = \text{max shear stress}$$

c is cohesion, σ is normal stress, ϕ is soil internal friction angle, j is shear deformation and k is shear modulus.

It was reported [40] that:

$$Z_0 = \left[\frac{P_{gr}}{K_c/b + K_\phi} \right]^{1/n} \quad MR = \left[\frac{b P_{gr}^{(n+1)/n}}{(n+1) \left[\frac{K_c}{b} + K_\phi \right]^{1/n}} \right] \quad (5)$$

Where Z_0 is maximum deformation, p_{gr} is average ground pressure equal to $p_c + p_i$, p_c is pressure due to carcass stiffness, p_i is tire inflation pressure and MR is motion resistance.

Reece [48] modified Eq. (3) to make it dimensionally more consistent. Reece's equation is as follows:

$$P = \left(cK'_c + \gamma b K'_\phi \right) \left(\frac{Z}{b} \right)^n \quad (6)$$

where K'_c , K'_ϕ , n = dimensionless constants and γ = weight density of soil. [49] found that predictions based on this equation were more consistent with their field data than were predictions made using Eq. (3).

According to Goering et al. [50], this approach has been useful for explaining some aspects of tractive device-soil interaction; however, semi-empirical approach has limited practical application.

6.3 Empirical Approach

This approach evolved at the end of World War II as a means of measuring trafficability of soil at the U.S. Army Corps of Engineers Waterways Experiment Station (WES). It was intended for quick numerical evaluation of soil in the field [40]. It is based on soil cone index as the only soil strength parameter. On the basis of numerous tests conducted at WES, primarily on fine-grained wet clay soil and coarse-grained dry Yuma sand, vehicle cone index (VCI) was developed to determine a “go-no go” criterion for military vehicles [41,51]. The VCI was based on measured soil cone index values. Goering et al. [50] reported that empirical methods using field and/or soil bin laboratory tests of traction devices either by themselves or as part of a complete vehicle are the most used technic for assessing tractive performance by both vehicle and traction device manufacturers.

Several empirical equations for traction prediction have been developed by researchers. Wismer and Luth [52] developed a traction prediction equation for a single powered wheel. The equation is an exponential function of travel reduction and is rewritten (Eq. 7) as:

$$NTR = \frac{P}{W} = 0.75(1 - e^{(-0.3C_n S)}) - \left(\frac{1.2}{C_n} + 0.04 \right) \quad (7)$$

Where NTR is net traction ration, P is net wheel pull, W is dynamic wheel load, C_n is wheel numeric,

($C_n = C.I.d.b/W$), CI is soil cone index, d is unloaded tire diameter, b is unloaded tire width and S is travel reduction (fraction). Wheel numeric is a simplified wheel-soil contact model based on dimensionless parameters. Wismer and Luth [52] also derived an equation for predicting the motion resistance ratio, which is the last expression of (Eq.7):

$$MRR = \frac{1.2}{C_n} + 0.04 \quad (8)$$

Where MRR is the motion resistance ratio, which is the ratio of the wheel motion resistance to the dynamic wheel load. The traction equation given by [53] takes a similar form as that developed by Wismer and Luth [52] to model mobility number, M . The equation is of the form (Eq. 9):

$$M = \frac{CIdb}{W} \left(\frac{\delta}{h} \right)^{0.5} \left[\frac{1}{1 + \frac{b}{2d}} \right] \quad (9)$$

where M is mobility number, δ is tire deflection and h is tire section height. The mobility includes wheel numeric used by Wismer and Luth [52]. Mobility number is used to predict the combined effect of soil-wheel parameters on the tractive performance.

Brixius et al. [6] presented traction prediction equations for single bias ply tires. His equations were revisions of equations developed by Wismer and Luth [52]. The equations are rewritten as:

$$\frac{GT}{W} = 0.88(1 - e^{(-0.1B_n)}) (1 - e^{(-7.5S)}) + 0.04 \quad (10)$$

$$MRR = \frac{1}{B_n} + 0.04 + \frac{0.5S}{B_n^{0.5}} \quad (11)$$

Where GT is gross traction and B_n is called mobility number defined by Brixius et al. [6] as (Eq. 12):

$$B_n = \frac{CIdb(1 + 5\delta/h)}{W(1 + 3b/d)} \quad (12)$$

These and several other researchers have reported several models for wheel numeric, motion resistance ratio and mobility number.

7. DEVELOPMENT OF SOIL BIN AT FUTA AND FUTURE WORK

Some efforts have been made to conduct research in soil dynamics in tillage at the department of Agricultural and Environmental Engineering of FUTA. The department has developed both indoor and outdoor soil bins (Figs. 7–9) and various studies have been reported [54,55,56,57,58,59,60]. Further work is in progress in soil dynamics in tillage and traction. Single wheel tester is being developed for another indoor soil bin in the Soil dynamics laboratory. Terrain characterization is also an area of study we need to research into.

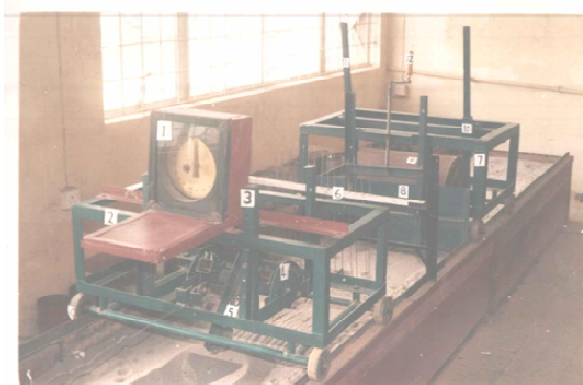

Fig. 7. An indoor soil bin at FUTA [55]



Fig. 8. Indoor soil bin (FUTA) with overhead gantry crane [57]



Fig. 9. Outdoor soil bin at FUTA [58]

8. CONCLUSIONS

Soil dynamics in traction has been reviewed with the aim of enlightening, motivating and challenging would-be researchers in the specialized field. It is noted that although a lot of

research has been done by researchers in developed countries, however there is a dearth of publication from Nigerian researchers.

Some efforts have been made by researchers at FUTA to study soil dynamics in tillage and more

efforts are required to intensify studies in traction which they have embarked upon.

COMPETING INTERESTS

Author has declared that no competing interests exist.

REFERENCES

1. Foth HD. Fundamental of soil science. 7th Edition. John Wiley and Sons. New York; 1984.
2. Culpin C. Farm machinery. 11th Edition English Language Book Society/Collins, London; 1986.
3. Yong RN, Fattah EA, Skiadas N. Vehicle Traction Mechanics. Elsevier Amsterdam; 1984.
4. Ani AO, Uzoejinwa BB, Ezeama AO, Ugwu SN, Ohagwu CJ, Odigbo EU. Soil bin facility for soil-machine interaction studies. Proceedings of the International Soil Tillage Research Organization. 2014;110–124.
5. Zoz FM, Grisso RD. Traction and tractor performance. ASAE Distinguished Lecture Series. Tractor Design No. 27. St. Joseph, Mich.: ASAE; 2003.
6. Brixius WW. Traction prediction equations for bias-ply tires. ASAE Paper No. 871622. St. Joseph, Mich.: ASAE; 1987.
7. Freitag DR. Dimensional analysis of performance of pneumatic tires on sand. Transactions of the ASAE. 1968;11(15):669–672.
8. Upadhyaya SK, Mehlschau J, Wulfsohn D, Glancey JL. Development of a unique, mobile, single wheel traction testing machine. American Society of Agricultural Engineers. 1986;25(9):1243–1246.
9. Patel NM, Godwin RJ. Controlled soil bin tests for pneumatic tyres at heavy loads. An ASABE Meeting Presentation. Paper Number: 083543 for 2008 ASABE Annual International Meeting, Providece, Rhode Island; 2008.
10. Yahya A, Zohadie M, Ahmad D, Elwaleed AK, Kheiralla AF. UPM indoor tyre traction testing facility. Journal of Terramechanics. 2007;44(2):293–301.
11. Taghavifar H, Mardani A. Contact area determination of agricultural tractor wheel with soil. Cercetari Agronomice in Moldova. 2012;XLV(2):15–20.
12. Taghavifar H, Mardani A. Analyses of energy dissipation of run-off-road wheeled vehicles utilizing controlled soil bin facility environment. Energy. 2014;66:973-980.
13. Ahmad D, Shamsuddin S, Fashina AB, Akande FB. Development of a tractor-pulled motion resistance test rig for traction studies on towed narrow wheels. 2011;4(4):21–27,1934-6344.
14. Taghavifar H, Mardani A. Net traction of a driven wheel as affected by slippage, velocity and wheel load. Journal of Saudi Society of Agricultural Sciences. 2015;14:167–171.
15. Burt EC, Reaves CA, Bailey AC, Pickering WD. A machine for testing tractor tires in soil bins. Trans. ASAE. 1980;23(3):546-547,552.
16. Lyne PWL, Burt EC, Jarrell JD. Computer control for the NTML single wheel tester. ASAE 1983, Paper No. 83-1555. St. Joseph, Mich.: ASAE.
17. Way TR. Three single wheel machines for traction research. ASABE Paper No. 07-1109. St. Joseph, Mich.: ASABE; 2007.
18. Wood RK, Wells LG. A soil bin to study compaction. ASAE Paper No. 83-1044. St. Joseph, Mich.: ASAE; 1983.
19. Wells LG, Buckles JD. PC-controlled soil/tire tester. ASAE Paper No. 87-1014. St. Joseph, Mich.: ASAE; 1987.
20. Rohlf RA, Wells LG, Xing ZX. Analysis of wheel compaction using a soil stress-strain finite element model. ASAE. Paper No. 94-1546. St. Joseph, Mich.: ASAE; 1994.
21. Wells LG, Yaping J, Xing ZX. Measuring three-dimensional soil deformation. Journal of Terramechanics. 1996;33(6):281-292.
22. Wu YC. Handling of multi-axle, all-wheel-drive off-road vehicles. PhD. diss. Ottawa: Carleton Univ., Dept. of Mechanical and Aerospace Engineering; 2000.
23. Krick G. Behaviour of tyres driven in soft ground with side slip. Journal of Terramechanics. 1973;9(4):9-30.
24. Godwin RJ, Brighton JL, Blackburn K, Richards TE, Ansorge D, Wheeler PN. Off road dynamics research at Cranfield University at Silsoe. ASABE Vol. Paper No. 06-1131. St. Joseph, Mich.: ASABE; 2006.
25. Way TR. Three single wheel machines for traction and soil compaction research agricultural engineering international: The CIGR Ejournal. Manuscript 1534. 2009;XI.
26. Dwyer MJ. Field measurement of agricultural tyre performance at the

- National Institute of Agricultural Engineering. In Proceedings 4th International Conference ISTVS. Hanover, N.H.: ISTVS. 1972;3:9-60.
27. Dwyer MJ. Predicting tractive performance. In Proceedings International Conference on Soil Dynamics. Auburn, Ala: Auburn University. 1985;4:679-692.
 28. Billington WP. The N.I.A.E. Mk II single wheel tester. Journal of Agricultural Engineering Resources. 1973;18:67-7.
 29. Maclaurin EB. The effect of tread pattern on the field performance of tyres. In Proceedings 7th International Conference ISTVS. Hanover, N.H.: ISTVS. 1981;2:699-735.
 30. Maclaurin EB. A rig for testing the soft soil performance of track systems. In Proceedings 8th International Conference ISTVS. Hanover, N.H.: ISTVS. 1984;1:291-311.
 31. Ronai D, Schmulevich I, Wolf D. A new field single wheel tester. In Extended Abstracts of the 2nd International Conference on Soil Dynamics. Silsoe, Bedford, UK: Silsoe College. 1994a;80-81.
 32. Ronai D, Schmulevich I, Wolf D. A new field single wheel tester. (This paper is supplemental to Extended Abstracts of the 2nd International Conference on Soil Dynamics. Silsoe, Bedford, UK: Silsoe College. 1994b;80-81.
 33. Plackett CW. A review of force prediction methods for off-road wheels. Journal of Agricultural Engineering Resource. 1985;31:1-29.
 34. Pandey KP, Tiwari GS. Rolling resistance of automobile discarded tyres for use in camel carts in sand. Presented at 2006 Annual international meeting of ASABE, Oregon Conventional center Portland, Oregon; 2006.
 35. Gill WR, Vanden Berg GE. Soil dynamics in tillage and traction. Handbook 316 Agricultural Research Service, U. S. Department of Agriculture, Washington, D. C; 1968.
 36. ASAE S296.5 General Terminology for traction of agricultural traction and transport devices and vehicles. ASAE, Standards. American Society of Agricultural and Biological Engineers, St. Joseph MI; 2009.
 37. Persson S. Basic traction mechanics. Advances in Soil Dynamics, ed. Upadhyaya SK, Chancellor WJ, Perumpral JV, Wulfsohn D, Way TR. Ch. 2, 25 - 58. St. Joseph, Mich.: ASABE. 2009;3.
 38. Upadhyaya SK. American society of agricultural engineers. Advances in soil dynamics. American Society of Agricultural Engineers; 1994.
 39. Mardani A, Shahidi K, Karim-Maslak H. An indoor traction measurement systems to facilitate research on agricultural tires. Journal of Food, Agriculture and Environment. 2010;8.
 40. Upadhyaya S. Traction prediction equations. Advances in Soil Dynamics, ed. Upadhyaya SK, Chancellor WJ, Perumpral JV, Wulfsohn D, Way TR. Ch. 2, 161 - 186. St. Joseph, Mich.: ASABE. 2009;3.
 41. Freitag DR. Soil dynamics as related to traction and transport systems. In Proceedings International Conference on Soil Dynamics. Auburn, Ala.: Auburn University. 1985;4:605-629.
 42. Wulfsohn D. Traction device-soil interfacial behavior. In Advances in Soil Dynamics. Upadhyaya SK, Chancellor WJ, Perumpral JV, Gill WR, Way TR, Wulfsohn D. eds. St. Joseph, Mich.: ASABE. 2009;3.
 43. Bekker MG. Off the road locomotion. University of Michigan Press, Ann Arbor; 1960.
 44. Wong JY. On the study of wheel-soil interaction. Journal of Terramechanics. 1984;21(2):117-131.
 45. Bekker MG. Introduction to terrain-vehicle systems. Ann Arbor, Michigan: University Michigan Press; 1969.
 46. Janosi Z, Hanamoto B. An analysis of the pull vs. slip relationship for track laying vehicles. Report No. 69. Warren, Mich.: Land Locomotion Laboratory; 1961a.
 47. Janosi Z, Hanamoto B. An analytical determination of drawbar pulls as a function of slip for tracked vehicles in deformable soils. Paper No. 41 in Proceedings of the 1st International Conference on the Mechanics of Soil-Vehicle Systems. ISTVS; 1961b.
 48. Reece AR. Problems of soil-vehicle mechanics. Land Locomotion Laboratory Report No. 8470 (LL97). Warren, Mich.: U.S. Army Tank Automotive Center; 1964.
 49. Upadhyaya SK, Wulfsohn D. Traction prediction using soil parameters obtained with an instrumented analog device. J. Terramechanics. 1993;30(2):85-100.
 50. Goering CE, Stone ML, Smith DE, Turnquist PK. Off-road vehicle engineering

- principles. American Society of Agricultural and Biological Engineers. 2006;351-379.
51. Wong JY. Terramechanics and Off-Road Vehicles. Elsevier; 1989.
 52. Wismer RD, Luth HJ. Off-road traction prediction for wheeled vehicles. Journal of Terramechanics. 1973;10(2):49-61.
 53. Gee-Clough D, Mcallister M, Pearson G, Evernden DW The empirical prediction of tractor implements field performance. Journal of Terramechanics. 1978;15(2):81-94.
 54. Manuwa SI. Development of equipment for soil tillage dynamics and evaluation of tillage parameters. PhD Thesis, Federal University of Technology, Akure, Nigeria. 2002;347.
 55. Manuwa SI, Ademosun OC. Draught and soil disturbance of model tillage tines under varying soil parameters. Agricultural Engineering International, the CIGR Ejournal (USA.). 2007;IX:1-18.
 56. Manuwa SI. Performance evaluation of tillage tines operating under different depths in a sandy clay loam soil. Soil and Tillage Research. 2009;103:399-405.
 57. Manuwa SI, Ajisafe AA. Development of overhead gantry as complementary equipment to indoor soil bin facility. Journal of Food Technology. 2010;8(3):92-95.
 58. Manuwa SI, Ademosun OC, Agbetoye AS, Adesina LAS. A development of outdoor soil bin facility for soil tillage dynamics research. Journal of Agricultural Engineering and Technology (JAET). 2011;19(1):1-8.
 59. Ajewole PO, Manuwa SI. Development of equipment for measuring pressure-sinkage behaviour of a heavy clay soil. Proceedings of 2014 International Soil Tillage Research Organisation (ISTRO) Nigeria Branch, held at the FUTA Hilltop Auditorium, Akure, Ondo State Nigeria. 2014a;84-93.
 60. Ajewole PO, Manuwa SI. Establishment of Bekker's model for predicting pressure-sinkage behaviour of loamy sand soil; 2014. Proceedings of the 15th International Conference and 35th AGM of the Nigeria Institution of Agricultural Engineers (NIAE), held at the FUTA Hilltop Auditorium, Akure, Ondo State Nigeria; 2014b.

© 2019 Sedara; This is an Open Access article distributed under the terms of the Creative Commons Attribution License (<http://creativecommons.org/licenses/by/4.0>), which permits unrestricted use, distribution, and reproduction in any medium, provided the original work is properly cited.

Peer-review history:

*The peer review history for this paper can be accessed here:
<http://www.sdiarticle3.com/review-history/48552>*